



### PROPOSAL REQUEST

**NUMBER: ONE**

Owner: Chickasha Public Schools  
900 West Choctaw Avenue  
Chickasha, Oklahoma 73018  
405-222-6500

Project: Grand Elementary School  
Chickasha Middle School

Contract For: Paving Improvements

Please submit an itemized proposal for work listed below. This proposal is to include labor and materials complete. Also, provide a timeline on delivery of materials and commencement of work for coordinating purposes.

#### 1. Description of Work

- Provide all site demolition as indicated per plans and specs.
- Provide all paving complete as indicated per plans and specs.
- Provide all concrete sidewalks as indicated per plans and specs.
- Provide all aggregate base as required.
- Provide all grading in all paved areas as necessary for sub-grade preparation.
- Provide all erosion control measures as required.
- Provide all solid slab sod at all disturbed areas as required by specs.
- Conduct all layouts, staking and surveying as required.
- Provide all pavement markings and signs, including all indicated signage as required.
- Provide all joint sealants and related accessories.
- Provide and install expansion joint assemblies as applicable to concrete work.
- All required work including, but not limited to, demolition, earthwork, erosion control, sod, site utilities, paving, striping, curbs, etc. to complete this scope of work is the responsibility of the awarded contractor.
- All work shall be conducted in compliance with all applicable state and federal laws/regulations including all safety, cleanliness, and waste management regulations, requirements, and precautions.

#### 2. Bidding Contracting Requirements

61 O.S. §107

- General: This Proposal Request is issued to solicit bids in compliance with the Public Competitive Bidding Act of 1974, Title 61 of the Oklahoma Statutes (61 O.S. §101et. Seq.)

### *Home of the Fightin' Chicks*

ADMINISTRATION	405-222-6500	BILL WALLACE ECC	405-222-6544	HEALTH SERVICES	405-222-6519
ADULT BASIC EDUCATION	405-222-6562	GRAND AVENUE	405-222-6524	MAINTENANCE	405-222-6500
ATHLETIC DEPARTMENT	405-222-6556	HIGH SCHOOL	405-222-6550	QUALITY ACADEMY	405-222-6506
CHILD NUTRITION	405-222-6573	LINCOLN	405-222-6520	TRANSPORTATION	405-222-6570
		MIDDLE SCHOOL	405-222-6530		

- Pursuant to state law, bids over \$50,000 will require a bid bond submitted with the sealed bid. The bid bond may be a certified check, a cashier's check or bid bond equal to five percent (5%) of the bid.
- A resultant contract award over \$50,000 will require statutory performance, payment and warranty bonds in an amount equal to the contract price.
- The contractor must provide general liability and workers compensation insurance, including employer's liability insurance, in amounts required by state law and as satisfactory to the owner.
- Include Notarized and Signed Non-Kickback Affidavit
- Include Notarized and Signed Sex Offender Affidavit

### 3. Mandatory Pre-Bid Conference

A mandatory pre-bid conference will be held on Tuesday, February 27<sup>th</sup>, 2024, at 10:00AM at the Grand Elementary School, located at 1415 W Grand Ave., Chickasha, Oklahoma.

### 4. Method of Response

Submit an itemized bid proposal with a firm total price on company letterhead. Clearly Mark Envelope: "Sealed Bid, Paving Improvements, Do Not Open"

Address Sealed Bids to:  
 Chickasha Public Schools  
 Attn: Superintendents Office  
 900 W Choctaw Ave.  
 Chickasha, OK 73018

Bids must arrive either by US Mail, Common Carrier or Hand Delivered no later than 2:00PM, March 14, 2024. Bids will be publicly opened and read aloud on March 14, 2024, at 2:00PM.

---

Requested By: Chickasha Public Schools

*Jan Gunn* *Executive Director of Operations*

(Signature)

(Title)

*2-21-24*

(Date)

SECTION INDEX

DIVISION 2 SITE CONSTRUCTION (CIVIL) SPECIFICATIONS

INDEX –

- 31 1000 – Site Clearing
- 31 2000 – Earth Moving
- 32 1216 – Asphalt Concrete Paving
- 32 1313 – Portland Cement Concrete Paving
- 32 1314 – Concrete Sidewalks, Curbs and Gutters
- 32 1317 – Pavement Marking
- 32 1318 – Traffic & Handicap Parking Signs
- 32 9223 – Sodding

Prepared By:

SMITH-ROBERTS BALDISCHWILER, LLC  
2500 McGee Drive, Suite 100  
Norman, Oklahoma 73072

By:

  
Daniel S. Andrulonis, P.E.  
13381

2-13-24

## **SECTION 31 1000**

### **SITE CLEARING**

#### **PART 1 GENERAL**

##### **1.01 RELATED DOCUMENTS**

- A. Drawings and general provisions of the Contract, including The City of Chickasha Standard Specifications for the Construction of Public Improvements.

##### **1.02 SECTION INCLUDES**

- A. Clearing and grubbing.
- B. Identification and protection of vegetation indicated to remain.
- C. Removal from site of paving, curbs, gutters, fences and miscellaneous structures.
- D. Removal, or disconnecting and capping, utilities and storm drains.
- E. Removal, storage and protection of site items designated, specified, or directed to be reinstalled.
- F. Identification and protection of site improvements indicated to remain.

##### **1.03 RELATED SECTIONS**

- A. Section 31 2000 – Earth Moving.
- B. Soils Report – Excavation, Filling and Backfilling for Buildings.
- C. Section 31 2320 – Trenching and Backfilling for Utilities.

##### **1.04 SUBMITTALS**

- A. Clearing procedures and operational sequence for review and acceptance by Engineer.

##### **1.05 QUALITY ASSURANCE**

- A. Use adequate numbers of skilled workmen who are thoroughly trained and experienced in the necessary crafts and who are completely familiar with the specified requirements and the methods needed for proper performance of the work of this Section.
- B. Regulatory Requirements: Comply with applicable requirements of federal, state, and local laws, regulations, and codes having jurisdiction at project site or applicable requirements of these standards and specifications, whichever is more stringent.

##### **1.06 PROJECT CONDITIONS**

- A. Coordination: Coordinate this work with the work of other Sections to avoid any delay or interference with other work.
- B. Traffic: Conduct work to ensure minimum interference with vehicular or pedestrian traffic and to permit unencumbered access to site and adjacent properties.
  - 1. Do not close or obstruct streets, sidewalks or public or private passageways without permission from Engineer or authorities having jurisdiction.
  - 2. If required by Engineer or governing authorities, provide alternate routes around closed or obstructed traffic ways.

#### **PART 2 PRODUCTS**

##### **2.01 MATERIALS**

- A. Provide materials, not specifically described but required for proper completion of the work of this Section, as selected by the Contractor subject to the approval of the Engineer.

##### **2.02 SEDIMENT DRAINAGE FABRIC**

- A. Non-biodegradable, sunlight stabilized, woven polypropylene fabric, type which will retain sediment and reduce water runoff velocity; one of the following by listed manufacturer, or approved equal:
  - 1. "Mirafi 100X Sedimentation Control Fabric" by Mirafi, Inc., Charlotte, NC (800) 438-1855.
  - 2. "Propex 1325 Embankment/Erosion Control Fabric" by Amoco Fabrics Company, Atlanta, GA (404) 955-0935.
  - 3. "Trevira Spunbond Engineering Fabric Style 1115 or 1120" by Hoechst Fibers Industries, New York, NY (212) 869-3850.

### **PART 3 EXECUTION**

#### **3.01 SURFACE CONDITIONS**

- A. Examine the areas and conditions under which work of this Section will be performed. Report in writing to Engineer all prevailing conditions that will adversely affect satisfactory execution of work. Correct conditions detrimental to timely and proper completion of the Work. Do not proceed until unsatisfactory conditions are corrected.
- B. Starting work constitutes acceptance of the existing conditions and this Contractor shall then, at his expense, be responsible for correcting all unsatisfactory and defective work encountered.

#### **3.02 PROTECTION**

- A. Protect existing utilities indicated or made known.
- B. Protect bench marks, monuments, and reference points from displacement or damage and, if displaced or damaged, replace at no cost to Owner.
- C. Protect trees and shrubs, where indicated to remain, so trees and shrubs will not be damaged in any way as part of this Work.
  - 1. Where trees are designated to remain on the site: Construct 2 x 4 wood barricades, minimum 3'-0" high around individual trees and groups of trees. Construct barricades at drip line.
  - 2. Protect tree root systems from damage due to deleterious materials caused by run-off or spillage during mixing, use or discarding of construction materials or drainage from stored materials. Protect root systems from compaction, flooding, erosion or excessive wetting.
  - 3. Engage a qualified tree surgeon to remove branches from trees, if required, to clear for new construction. Where directed by Engineer, extend pruning operations to restore natural shape of entire tree.
  - 4. Where cutting is required, tree surgeon shall cut branches and roots with sharp pruning instruments; do not break or chop. Paint cuts over ½" in size with standard tree paint or compound which is waterproof, antiseptic, elastic and free of kerosene, coal tar, creosote and other substances harmful to plants.
  - 5. Store no construction materials, debris, or excavated material within drip line. Permit no vehicular traffic or parking within drip line.
  - 6. Repair for Damaged Trees:
    - a. Engage a qualified tree surgeon to perform tree repair work.
    - b. Make repairs promptly after damage occurs to prevent progressive deterioration of damaged trees.
    - c. Remove dead trees and damaged trees which are determined by the tree surgeon to be incapable of restoration to normal growth pattern.
- D. Protection of Persons and Property:
  - 1. Barricade open depressions and holes occurring as part of this Work, and post warning lights on property adjacent to or with public access.
  - 2. Operate warning lights during hours from dusk to dawn each day and as otherwise required.
  - 3. Protect structures, utilities, sidewalks, pavements, and other facilities from damage caused by settlement, lateral movement, undermining, washout, and other hazards created by operations under this Section.
- E. Use means necessary to prevent dust becoming a nuisance to the public, to neighbors, and to other work being performed on or near the site.
- F. Maintain access to the site at all times.

### **3.03 EROSION AND SEDIMENT CONTROL**

- A. Plan and execute clearing operations to control erosion and sedimentation.
- B. Sediment Barriers:
  - 1. Install prior to commencing grubbing operations.
  - 2. Install as shown on drawings at all locations where water flows from construction areas, including entire perimeter of construction areas where ground slopes outward and at drainage structure inlets. Maintain around drainage structures until establishment of vegetation in grassed and landscaped areas or until construction of surfacing in paved areas.
  - 3. Arrange to create ponding behind barriers; remove accumulated sediments and maintain ponding capacity during construction.
  - 4. Sediments shall be removed from flowing water by filtration. Primary filter media shall consist of anchored sediment drainage fabric and straw bales staked or otherwise held securely in place.

### **3.04 CLEARING**

- A. Remove trees, shrubs, stumps, bushes, vines, rubbish, undergrowth, deadwood as well as fences and incidental structures from site except as otherwise designated on the drawings to remain.

### **3.05 GRUBBING**

- A. Clean out roots 1" in diameter and larger to a depth of at least 12" below the existing ground surface or subgrade of new graded surface, whichever is lower. Treat roots remaining in the soil with a weed killer approved by the Engineer.
- B. Backfill and compact holes resulting from stump and root removal operations. Comply with requirements specified in Section 31 2320 for backfill materials, compaction, and installation methods.

### **3.06 BELOW GRADE REMOVAL**

- A. Clean out rubbish and incidental structures below the existing ground surface.
- B. Backfill and compact holes resulting from below grade removal operations. Comply with requirements specified in the Soils Report for backfill materials, compaction, and installation methods.

### **3.07 DISPOSAL**

- A. General:
  - 1. Remove brush, grass, roots, trash, and other material from clearing operations.
  - 2. Dispose of away from the site in a legal manner.
  - 3. Do not store or permit debris to accumulate on the job site.
- B. Do not burn debris at the site.
- C. Remove tools, equipment and protection when work is complete and when authorized to do so by local authorities having jurisdiction and Engineer.

### **3.08 UTILITIES**

- A. Coordinate with utility companies and agencies as required. Contact local utility companies 48 hours minimum prior to start of demolition work. Confirm verbal notices and written notices. Verify locations of all utilities entering site and their locations on site.
- B. Where utility cutting, capping, or plugging is required, perform such work in accordance with requirements of the utility company or governmental agency having jurisdiction.

**END OF SECTION**

## **SECTION 31 2000**

### **EARTH MOVING**

#### **PART 1 GENERAL**

##### **1.01 RELATED DOCUMENTS**

- A. Drawings and general provisions of the Contract, including The City of Chickasha Standard Specifications for the Construction of Public Improvements.

##### **1.02 SECTION INCLUDES**

- A. Removal of topsoil, stockpiling on site for later use.
- B. Excavation of sub-soil to required grades, contours, and levels and compaction of subgrade.
- C. Placing excavated sub-soil and borrow material in fills to required grades, contours and levels and compaction of each fill lift and subgrade.
- D. Obtaining and transporting to site borrow material, if required.
- E. Transporting from site and disposing of waste material, including excess topsoil, if required.
- F. Finish grading of subgrade.
- G. Placing, finish grading, and compaction of topsoil.

##### **1.03 RELATED SECTIONS**

- A. Section 31 1000 – Site Clearing.
- B. Soils Report – Excavation, Filling And Backfilling For Buildings.
- C. Section 31 2320 – Trenching And Backfilling For Utilities.
- D. Section 31 3116 – Termite Control.
- E. Section 32 1313 – Portland Cement Concrete Paving.
- F. Section 32 1314 – Concrete Sidewalks, Curbs and Gutters.
- G. Section 32 9223 – Sodding.

##### **1.04 SUBMITTALS**

- A. Submit 2 copies of following test reports:
  - 1. Field density, moisture, and gradation test reports of each test made.
  - 2. Laboratory test results for each type of soil encountered.

##### **1.05 QUALITY ASSURANCE**

- A. Use adequate numbers of skilled workmen who are thoroughly trained and experienced in the necessary crafts and who are completely familiar with the specified requirements and the methods needed for proper performance of the work of this Section.
- B. Use equipment adequate in size, capacity, and numbers to accomplish the work in a timely manner.
- C. In addition to complying with requirements of governmental agencies having jurisdiction, comply with the directions of the Soil Engineer.
- D. Testing Services: By independent commercial testing laboratory employed and paid by Contractor, acceptable to Engineer.
- E. Moisture-Density Relations of Soils: ANSI/ASTM D 698 (Standard Proctor Method).

##### **1.06 PROJECT CONDITIONS**

- A. Confine equipment, apparatus, materials, storage, and operations of workers to limits provided by law, ordinances, permits, contract documents, and as directed.

- B. Keep dirt, dust, noise, and other objectionable nuisances arising from grading operations to a minimum.
- C. Equipment: Type approved prior to use, with proven capability to perform work in acceptable manner, as recommended by manufacturer for use intended. Perform compaction using tamping rollers, pneumatic tired rollers, three- wheeled power rollers, or other approved type equipment.

## **PART 2 PRODUCTS**

### **2.01 SOIL MATERIALS**

- A. Fill and Backfill Materials:
  - 1. Provide soil materials free from organic matter, building debris, frozen material, vegetable matter and other deleterious substances, containing no rocks or lumps over 3" in greatest dimension.
  - 2. Satisfactory Material: Fill material is subject to the approval of the Soil Engineer, and is that material removed from excavations or imported from off-site borrow areas, free from roots and other deleterious matter.
  - 3. Unsatisfactory Material: Man-made fills, refuse, or backfills from previous construction, soils not approved for use by the Soil Engineer and soils with USC classifications OL, MH, CH, OH, ML GC and PT, generally described as follows:
    - a. Peat, mulch and other highly organic swamp soils.
    - b. Organic and inorganic clays of medium to high plasticity.
    - c. Elastic silts.
    - d. Other soils not suitable for the intended construction.
  - 4. Do not permit rocks having a dimension greater than 1" in the upper 12" of fill or embankment.
  - 5. Cohesionless material used for structural backfill: Provide sand free from organic material and other foreign matter, and as approved by the Soil Engineer.
  - 6. Inert fill placed under structures and pavement shall consist of imported fill or native soil stabilized with lime or fly ash. Inert fill shall meet the following requirements:
    - Amount finer than 2" sieve = 100%
    - Amount finer than No. 200 sieve = 12% minimum and if  $PI \leq 7$ , 60% maximum
    - Liquid Limit = 40 maximum
    - Plasticity Index = 17 maximum
- B. Satisfactory Soil Materials:
  - 1. In fill areas provide materials as required to obtain the grades shown on the Drawings.
    - a. ASTM D 2487 Soil Classification Groups GW, GM, SW, SM, SC, CL; Liquid Limit (LL) less than 40; Plastic Index (PI) between 7 and 20; if granular, minimum of 20% must pass No. 200 sieve.

### **2.02 WEED KILLER**

- A. Provide a dry, free-flowing, dust-free chemical compound soluble in water, capable of inhibiting growth of vegetation, and approved for use on this Work by governmental agencies having jurisdiction.

### **2.03 TOPSOIL**

- A. For areas not covered by building, drives, parking lots, walks or other hard surfaces, provide topsoil consisting of friable, fertile soil of loamy character, containing an amount of organic matter normal to the region, capable of sustaining healthy plant life, and reasonably free from subsoils, roots, heavy or stiff clay, stones larger than 2" in greatest dimension, noxious weeds, sticks, brush, litter, and other deleterious matter.
- B. Obtain topsoil from sources within the project limits, or provide imported topsoil obtained from sources outside the project limits, or from both sources.

### **2.04 GEOTEXTILE FABRIC**

- A. Filter Fabric: Manufacturer's standard nonwoven pervious geotextile fabric of polypropylene, nylon or polyester fibers, or a combination. Provide filter fabrics that meet or exceed the listed minimum physical properties determined according to ASTM D 4759.
  - 1. Grab Tensile Strength (ASTM D 4632): 100 lb.



2. Apparent Opening Size (ASTM D 4751): #100 U.S. Standard sieve.
3. Permeability (ASTM D 4491): 150 gallons per minute per sq. ft.

## **2.05 GRADED AGGREGATE**

- A. Graded aggregate shall conform to the requirements of Section 703.01 of the Oklahoma Department of Transportation Standard Specifications for Highway Construction, Latest Edition.

## **PART 3 EXECUTION**

### **3.01 SURFACE CONDITIONS**

- A. Examine the areas and conditions under which work of this Section will be performed. Correct conditions detrimental to timely and proper completion of the Work. Do not proceed until unsatisfactory conditions are corrected.

### **3.02 FINISH ELEVATIONS AND LINES**

- A. Comply with pertinent provisions of Division I Specifications.
- B. Establish and identify required lines, levels, contours, and datum.

### **3.03 PROTECTION**

- A. Utilities:
  1. Unless shown to be removed, protect active utility lines shown on the Drawings or otherwise made known to the Contractor prior to excavating. If damaged, repair or replace at no additional cost to the Owner.
  2. If active utility lines are encountered, and are not shown on the Drawings or otherwise made known to the Contractor, promptly take necessary steps to assure that service is not interrupted.
  3. If service is interrupted as a result of work under this Section, immediately restore service by repairing the damaged utility at no additional cost to the Owner.
  4. If existing utilities are found to interfere with the permanent facilities being constructed under this Section, immediately notify the Engineer and secure his instructions.
  5. Do not proceed with permanent relocation of utilities until written instructions are received from the Engineer.
- B. Maintain bench marks, monuments, and other reference points. Reestablish if disturbed or destroyed, at no additional cost to Owner.
- C. Protect trees and shrubs, where indicated to remain, so trees and shrubs will not be damaged in any way as part of this Work.
  1. Excavation Around Trees to Remain:
    - a. Where excavating is required within drip line of trees, hand excavate to minimize damage to root systems and provide sheeting at excavations if required. Use narrow tine spading forks and comb soil to expose roots. Relocate roots in backfill areas. If large, main lateral roots are encountered, exposed beyond excavation limits, bend and relocate without breaking. If encountered immediately adjacent to location of new construction and relocation is not practical, put roots approximately 3" back from new construction.
    - b. Allow no exposed roots to dry out before permanent backfill is placed; provide temporary earth cover, or pack with peat moss and wrap with burlap. Water and maintain in moist condition and temporarily support and protect from damage until permanently relocated and covered with backfill.
    - c. Prune branches in accordance with standard horticultural practice to balance loss to root system caused by damage or cutting of root system. Engage qualified tree surgeon to prune branches.
  2. Grading and Filling Around Trees Near Grading Limits:
    - a. Existing Grades: Maintain existing grading within drip line of trees, unless otherwise indicated on the drawings.
    - b. Lowering Grades: Where existing grade is above new finish grade shown around trees, carefully hand excavate within drip line to new finish grade. Cut roots exposed by excavation or provide permanent protection as recommended by tree surgeon.

- c. Raising Grades, Minor Fill: Where existing grade is 6" or less below elevation of finish grade shown, use a topsoil fill mixture. Place a single layer and do not compact; hand grade to required finish elevations.
  - d. Raising Grades, Moderate Fills: Where existing grade is more than 6" but less than 12" below finish grade elevation, place layer of drainage fill on existing grade prior to placing topsoil. Carefully place against trunk of tree approximately 2" above finish grade elevation and extend not less than 18" from tree trunk on all sides. For balance of area within drip line perimeter, place drainage fill to an elevation of 6" below grade and complete fill with a layer of topsoil to finish grade elevation. Do not compact stone or gravel or topsoil layers, and grade to required elevations.
3. Repair for Damaged Trees:
- a. Engage a qualified tree surgeon to perform tree repair work.
  - b. Make repairs promptly after damage occurs to prevent progressive deterioration of damaged trees.
  - c. Remove dead trees and damaged trees which are determined by the tree surgeon to be incapable of restoration to normal growth pattern.
- D. Protection of Persons and Property:
- 1. Barricade open holes and depressions occurring as part of this Work, and post warning lights on property adjacent to or with public access.
  - 2. Operate warning lights during hours from dusk to dawn each day and as otherwise required.
  - 3. Protect structures, utilities, sidewalks, pavements, and other facilities from damage caused by settlement, lateral movement, undermining, washout, and other hazards created by operations under this Section.
- E. Dewatering:
- 1. Remove all water, including rain water, encountered during trench and substructure work to an approved location by pumps, drains, and other approved methods.
  - 2. Keep excavations and site construction area free from water.
- F. Use means necessary to prevent dust becoming a nuisance to the public, to neighbors, and to other work being performed on or near the site.
- G. Maintain access to adjacent areas at all times.

### **3.04 CONSERVATION OF TOPSOIL**

- A. After the area has been cleared of vegetation, strip the existing topsoil from areas to be excavated, filled, or regraded. Strip to 8" minimum depth, without contamination with subsoils. Keep free of roots, stones and other undesirable materials. Do not strip topsoil when wet.
- B. Stockpile enough topsoil to provide at least 6" depth of topsoil in areas not covered by building, drives, parking lots, walks, or other hard surfaces and to fill planting beds and planters.
- C. Stockpile in an area clear of new construction and convenient to areas shown to receive topsoil later. If directed, spread in areas prepared to receive topsoil. Do not drive heavy equipment over stockpiled or spread topsoil. Do not stockpile to depth exceeding 4-ft.
- D. Maintain the stockpile in a manner which will not obstruct the natural flow of drainage.
  - 1. Maintain stockpile free from debris and trash.
  - 2. Keep the topsoil damp to prevent dust and drying out.
- E. Surplus Topsoil:
  - 1. Dispose of surplus topsoil, away from the site at disposal areas arranged and paid for by the Contractor.

### **3.05 EXCAVATING**

- A. Perform excavating of every type of material encountered within the limits of the Work to the lines, grades, and elevations indicated and specified herein. Excavation shall be unclassified, regardless of nature of material encountered. Examine site prior to bidding and include cost of rock excavation encountered.

- B. Satisfactory Excavated Materials:
  - 1. Transport to, and place in, fill or embankment areas within the limits of the Work.
- C. Unsatisfactory Excavated Materials:
  - 1. Excavate to a distance below grade as directed by the Soil Engineer, and replace with satisfactory materials.
  - 2. Include excavation of unsatisfactory materials, and replacement by satisfactory materials, as parts of the work of this Section.
- D. Surplus Materials:
  - 1. Dispose of unsatisfactory excavated materials, and surplus satisfactory excavated materials, on the Owner's property as directed by the Engineer.
- E. Excavation of Rock:
  - 1. Where rocks, boulders, granite, or similar materials is encountered, and where such material cannot be removed or excavated by conventional earth moving or ripping equipment, take required steps to proceed with the general grading operations of the Work, and remove or excavate such material by means which will neither cause additional cost to the Owner nor endanger buildings or structures whether on or off the site. Remove to following depths:
    - a. Under Walks, Building and Paving: To underside of their respective subgrade, as shown on drawings.
    - b. Under Grass Areas: To 12" below finish grade.
    - c. Under Shrub or Flower Beds: To 24" below finish grade.
    - d. Under Trees: To depth below finish grade as shown on landscape drawings.
  - 2. Do not use explosives.
- F. Excavate and backfill in a manner and sequence that will provide proper drainage at all times.
- G. Ditches and Gutters:
  - 1. Cut accurately to the cross sections, grades, and elevations shown.
  - 2. Maintain excavations free from detrimental quantities of leaves, sticks, trash, and other debris until completion of the Work.
  - 3. Dispose of excavated materials as shown on the Drawings or directed by the Soil Engineer; except do not, in any case, deposit materials less than 3'-0" from the edge of a ditch.
- H. Unauthorized Excavation:
  - 1. Unauthorized excavation consists of removal of materials beyond indicated subgrade elevations or dimensions without specific instruction from the Engineer or the Soil Engineer.
  - 2. Under footings, foundations, or retaining walls:
    - a. Fill unauthorized excavation by extending the indicated bottom elevation of the footing or base to the excavation bottom, without altering the required top elevation.
    - b. When acceptable to the Soil Engineer, lean concrete fill may be used to bring bottom elevations to proper position.
  - 3. Elsewhere, backfill and compact unauthorized excavations as specified for authorized excavations, unless otherwise directed by the Soil Engineer.
- I. Stability of Excavations:
  - 1. Slope sides of excavation to 1:1 or flatter, unless otherwise directed by the Soil Engineer.
  - 2. Shore and brace where sloping is not possible because of space restrictions or stability of the materials being excavated.
  - 3. Maintain sides and slopes of excavations in a safe condition until completion of backfilling.
- J. Shoring and Bracing:
  - 1. Provide materials for shoring and bracing as may be necessary for safety of personnel, protection of work, and compliance with requirements of governmental agencies having jurisdiction.
  - 2. Maintain shoring and bracing in excavations regardless of the time period excavations will be open.
  - 3. Carry shoring and bracing down as excavation progresses.

### **3.06 FILLING AND BACKFILLING**

- A. Backfill excavations as promptly as progress of the Work permits, but not until:
  - 1. Acceptance of construction below finish grade;
  - 2. Inspecting, testing, approving, and recording locations of underground utilities;
  - 3. Concrete formwork is removed;
  - 4. Shoring and bracing are removed, and voids have been backfilled with satisfactory materials;
  - 5. Trash and debris have been removed; and
  - 6. Horizontal bracing is in place on horizontally supported walls.
  
- B. Ground Surface Preparation:
  - 1. Remove vegetation, debris, unsatisfactory soil materials, obstructions, and deleterious materials from the ground surface prior to placement of fills.
  - 2. Scarify to a depth of 9" and proof roll ground surface prior to placement of fills. Remove soft material, fill resulting excavation with satisfactory material, and compact as required by this specification.
  - 3. Plow, strip, or break up surfaces steeper than one vertical to four horizontal, so that fill material will bond with existing surface.
  - 4. When existing ground surface has a density less than that specified under "compacting" for the particular area, break up the ground surface, pulverize, moisture-condition to the optimum moisture content, and compact to required depth and percentage of maximum density.
  - 5. At exposed soils in areas to be paved, scarify to a minimum depth of 8", and recompact at a moisture content that will permit proper compaction as specified for fill.
  
- C. Placing and Compacting:
  - 1. Place backfill and fill materials in layers not more than 8" in loose depth.
  - 2. Before compacting, moisten or aerate each layer as necessary to provide the optimum moisture content.
  - 3. Compact each layer to required percentage of maximum density for the area.
  - 4. Do not place backfill or fill material on surfaces that are muddy, frozen, or containing frost or ice.
  - 5. Place backfill and fill materials evenly adjacent to structures, to required elevations.
  - 6. Take care to prevent wedging action of backfill against structures by carrying the material uniformly around the structures to approximately the same elevation in each lift.
  - 7. Place a minimum of 1.0 feet of inert material or native soils modified with fly ash or lime under building pad.

### **3.07 FINISH GRADING**

- A. General:
  - 1. Uniformly grade the areas within limits of grading under this Section, including adjacent transition areas.
  - 2. Smooth the finished surfaces within specified tolerance.
  - 3. Compact with uniform levels or slopes between points where elevations are shown on the Drawings, or between such points and existing grades.
  - 4. Where a change of slope is indicated on the Drawings, radius of approximately 8'-0", unless adjacent construction will not permit such a transition, or if such a transition defeats positive control of drainage.
  
- B. Grading Outside Building Lines:
  - 1. Grade areas adjacent to buildings to achieve drainage away from the structures, and to prevent ponding.
  - 2. Finish the surfaces to be free from irregular surface changes, and:
    - a. Shape the surface of areas scheduled to be under walks to line, grade, and cross-section, with finished surface not more than 0.10 ft above or below the required subgrade elevation.
    - b. Shape the surface of areas scheduled to be under pavement to line, grade, and cross-section, with finished surface not more than 0.05 ft above or below the required subgrade elevation.

### **3.08 COMPACTING**

- A. Control soil compaction during construction to provide the minimum percentage of density specified for each area as determined according to ASTM D 698. Limit compaction by hand or hand-operated machines to areas less than 10 feet in width.

- B. Provide not less than the following percentage of maximum density of soil material compacted at plus or minus 2% of optimum moisture content for the actual density of each layer of soil material in place, and as approved by the Soil Engineer.
  - 1. Structures:
    - a. Compact the top 8" of subgrade and each layer of fill material or backfill material at 95% of maximum density.
  - 2. Walks:
    - a. Compact the top 6" of subgrade and each layer of fill material or backfill material at 95% of maximum density.
  - 3. Pavements:
    - a. Compact the top 8" of subgrade and each layer of fill material or backfill material at 95% of maximum density.
  - 4. Lawn and Unpaved Areas:
    - a. Compact each layer of fill material or backfill material at 95% of maximum density.
    - b. Compact the upper 12" of filled areas, or natural soils exposed by excavating or topsoil removal, at 90% of maximum density.
- C. Moisture Control:
  - 1. Where subgrade or layer of soil material must be moisture-conditioned before compacting, uniformly apply water to surface of subgrade or layer of soil material to prevent free water appearing on surface during or subsequent to compacting operations.
  - 2. Remove and replace, or scarify and air dry, soil material that is too wet to permit compacting to the specified density.
  - 3. Soil material that has been removed because it is too wet to permit compacting may be stockpiled or spread and allowed to dry. Assist drying by discing, harrowing, or pulverizing until moisture content is reduced to a satisfactory value as determined by moisture-density relation tests approved by the Soil Engineer.

### **3.09 EROSION AND SEDIMENT CONTROL**

- A. Provide during construction until permanent pavement, plantings and restoration of natural areas is effective in controlling erosion at site.
- B. Plan and execute construction by methods to control surface drainage from cut, fill, borrow, and grading areas.
  - 1. Minimize amount of bare soil exposed at one time.
  - 2. Schedule operations so ground surface will be disturbed for shortest possible time before permanent construction is installed.
  - 3. Maintain large areas as flat as practicable to minimize soil transport through surface flow.
  - 4. Where steep slopes or abrupt grade changes occur, install temporary diversion berm or dike at top of slope to direct water flow to a control point to be transported downslope in a slope drain. In all cases, do not allow water to flow uncontrolled down slopes.
- C. Slope Drains: Construct pipe, fiber mats, rubble, portland cement concrete, asphaltic concrete, plastic sheets, or similar materials approved by Engineer. Install to convey water down slopes, complete with apron at top to direct water into the drain and to anchor it in place and stone or rubble placed at outlets to prevent scouring of soil.
- D. Ground Cover: Protect all exposed soils sloping 7% or greater until construction of permanent surfaces begins.
  - 1. Use straw or other mulches, stone base, plastic sheets, fiber mats, or other effective erosion treatments approved by Engineer.
- E. Sediment Barriers: Maintain sediment barriers installed during clearing operations. Repair as necessary to maintain effectiveness.
- F. Repair washed and eroded areas; reestablish grades to required density, elevations, profiles and contours.

### **3.10 SAMPLING AND TESTING**

- A. Secure the testing laboratory's inspection and approval of subgrades and fill layers before subsequent construction is permitted thereon.
- B. Density Tests and Reports:
  - 1. Field in-place density shall be determined in accordance with ASTM D 1556 or ASTM D 2922. When ASTM D 2922 is used, the calibration curves shall be checked and adjusted using only the sand cone method as described in ASTM D 1556. ASTM D 2922 results in a wet unit weight of soil and when using this method ASTM D 3017 shall be used to determine the moisture content of the soil. The calibration curves furnished with the moisture gauges shall also be checked along with density calibration checks as described in ASTM D 3017. The calibration checks of both the density and moisture gauges shall be made at the beginning of a job on each different type of material encountered and in intervals as directed by this specification section and the Engineer.
  - 2. ASTM D 2937, the Drive Cylinder Method shall be used only for soft, fine-grained, cohesive soils.
  - 3. Within 24 hours of conclusion of physical tests, 2 copies of test results, including calibration curves and results of calibration tests, shall be furnished to the Engineer. Inspections and test results shall be certified by a registered professional civil engineer. These certifications shall state that the tests and observations were performed by or under the direct supervision of the engineer and that the results are representative of the materials or conditions being certified by the tests.
- C. Maximum Density and Soil Classification: Tests shall be made for each type material or source of material including borrow material.
  - 1. Determine the optimum moisture and laboratory maximum density values in accordance with ASTM D 698 .
  - 2. Determine the Atterberg Limits and Consistency Indexes.
    - a. Liquid Limit shall be determined in accordance with AASHTO T 89.
    - b. Plastic Limit and Plasticity Index shall be determined in accordance with AASHTO T 90.
    - c. Shrinkage Limit shall be determined in accordance with AASHTO T 92.
  - 3. Determine the gradation in accordance with ASTM C 136, ASTM D 422 or ASTM D 1140.
- D. Fill and Backfill Material Gradation:
  - 1. One test per 2,000 cubic yards stockpiled or in-place source material. Gradation of fill and backfill material shall be determined in accordance with ASTM C 136, ASTM D 422 or ASTM D 1140.
- E. Moisture Contents:
  - 1. In the stockpile, excavation or borrow areas, a minimum of two tests per day per type of material or source of material being placed during stable weather conditions.
  - 2. During unstable weather, tests shall be made as dictated by local conditions and approved by the Engineer.
  - 3. Moisture contents shall be tested in accordance with ASTM D 2216.
- F. In-Place Density and Moisture Content of Subgrades:
  - 1. One test per 1,200 square yards or fraction thereof under pavements.
  - 2. One test per 600 square yards or fraction thereof under building slabs-on-grade.
- G. In-Place Density and Moisture Content of Fills and Backfills:
  - 1. One test per 1,200 square yards or fraction thereof of each lift for fill or backfill in areas other than under building slabs-on-grade compacted by other than hand or hand-operated machines.
  - 2. One test per 600 square yards or fraction thereof of each lift for fill or backfill in areas under building slabs-on-grade compacted by other than hand or hand-operated machines.
  - 3. The density for each lift of fill or backfill materials for trenches, pits, building perimeters or other structures or areas less than 10 feet in width, which are compacted with hand or hand-operated machines shall be tested as follows: One test per each area less than 200 square yards, or one test for each 200 linear feet of long narrow fills under building and paving areas and one test for each 600 linear feet of long narrow fills in other areas.
  - 4. If ASTM D 2922 is used, in-place densities shall be checked by ASTM D 1556 as follows: One check per lift for each 1,000 linear feet of long narrow fills under building and paving areas, one

check lift for each 2,000 linear feet of long narrow fills in other areas, and a minimum of 2 checks per lift for other fill and backfill areas.

- H. If, in the Soil Engineer's opinion based on reports of the testing laboratory, subgrade or fills which have been placed are below specified density, provide additional compacting and testing under the provisions of the Division I Specifications.

### **3.11 TOPSOILING**

- A. Location: Apply on areas within project grading limits, except in areas shown covered by buildings, walks and pavings.
- B. Installation:
  - 1. Use topsoil in relative dry state. Do not place in wet or freezing weather.
  - 2. Fine grade to eliminate rough and low areas and to ensure positive drainage, to smoothness suitable for grass seeding or sprigging. Maintain levels, profiles and contours of subgrade.
  - 3. Remove stones, roots, grass, weeds, trash, debris and other foreign material while spreading.
  - 4. Manually spread around trees, plants, buildings and other on-site improvements which might be damaged by grading equipment.
  - 5. Place during dry weather, to following minimum depths to bring grades up to required finished grade elevations:
    - a. For Grass Seeding, Sprigging or Sodding: 6" depth.
    - b. For Shrub Beds: 24" depth.
    - c. For Flower Beds: 18" depth.
    - d. For Trees: To depth shown on landscape drawings.
  - 6. Compact topsoiled areas to 90% of Standard Proctor Density, unless directed otherwise.

### **3.12 MAINTENANCE**

- A. Protection of newly graded areas:
  - 1. Protect newly graded areas from traffic and erosion, and keep free from trash and weeds;
  - 2. Repair and reestablish grades in settled, eroded, and rutted areas to the specified tolerances.
- B. Where completed compacted areas are disturbed by subsequent construction operations or adverse weather, scarify the surface, reshape, and compact to the required density prior to further construction.

### **3.13 CERTIFICATION**

- A. Upon completion of this portion of the Work, and as a condition of its acceptance, deliver to the Engineer a written report from the testing laboratory certifying that the compaction requirements have been obtained. State in the report the area of fill or embankment, the compaction density obtained, and the type or classification of fill material placed.

**END OF SECTION**

**SECTION 32 1216**  
**ASPHALT CONCRETE PAVING**

**PART 1 GENERAL**

**1.01 RELATED DOCUMENTS**

- A. Drawings and general provisions of the Contract, including The City of Chickasha Standard Specifications for the Construction of Public Improvements.

**1.02 SECTION INCLUDES**

- A. Applying prime coat.
- B. Applying tack coat.
- C. Placing and compacting asphalt concrete.
- D. Parking lot striping and handicapped signage painting.

**1.03 RELATED SECTIONS**

- A. Section 31 2000 – Earth Moving.
- B. Section 32 1215 – Stabilized Subgrade.
- B. Section 32 1314 – Concrete Sidewalks, Curbs and Gutters.
- C. Section 32 1317 – Pavement Marking.
- D. Section 32 1318 – Traffic and Handicap Parking Signs.

**1.04 SUBMITTALS**

- A. Product Data: Within 35 calendar days after the Contractor has received the Owner's Notice to Proceed, submit:
  - 1. Materials list of items proposed to be provided under this Section;
  - 2. Certificates, signed by the materials producer and the asphalt paving subcontractor, stating that materials meet or exceed the specified requirements.
- B. Submit 2 copies of following test reports:
  - 1. Paving Job-Mix Formula: Indicate percentage of each sieve-fraction of aggregate and percentage of bitumen for each type of asphalt paving specified; obtain written approval prior to purchase or use.
  - 2. Field density, gradation and asphalt content for each test made.

**1.05 QUALITY ASSURANCE**

- A. Use adequate numbers of skilled workmen who are thoroughly trained and experienced in the necessary crafts and who are completely familiar with the specified requirements and the methods for proper performance of the work of this Section.
- B. Equipment: Type approved prior to use, for capability of equipment to perform acceptable work.
- C. Do not commence placement of asphalt until mix designs have been reviewed and approved by the Engineer and all governmental agencies having jurisdiction, and until copies of the approved mix designs are at the job site and the batch plant.
- D. Provide access for, and cooperate with, the inspector and testing laboratory.
- E. Testing Services: By independent commercial testing laboratory employed and paid by Contractor, acceptable to Engineer.
- F. Moisture-Density Relations of Soils: ANSI/ASTM D 698 (Standard Proctor Method).
- G. Reference Standards: Referenced portions of Oklahoma Department of Transportation "Standard Specifications for Highway Construction", Latest Edition as amended to date, as referenced herein as "ODOT Specifications".
  - 1. Delete "Basis of Payment" since this is a lump sum contract.

**1.06 PROJECT CONDITIONS**

- A. Confine equipment, apparatus, materials, storage and operations of workers to limits provided by law, ordinances, permits, contract documents, and as directed.



## **1.07 WEATHER LIMITATIONS**

- A. Apply prime and tack coats only when ambient temperature is above 45°F. and when temperature has not been below 35°F. for 12 hours immediately prior to application. Do not apply when base is wet or contains an excess of moisture.
- B. Construct asphalt concrete courses when atmospheric temperature is above 45°F. and when base is clean and dry.

## **PART 2 PRODUCTS**

### **2.01 ASPHALT CONCRETE**

- A. Use locally available materials and gradations which exhibit satisfactory record of previous installations.
- B. Surface Course: ODOT Specifications Section 411; Hot mix-Hot laid Type B (100% passing 3/4" sieve) asphalt meeting requirements of ODOT Specifications Section 708.
- C. Base Course: ODOT Specifications Section 411; Hot mix-Hot laid Type A (100% passing 1½" sieve) asphalt meeting requirements of ODOT Specifications Section 708.

### **2.02 TACK AND PRIME COAT**

- A. Tack Coat: Cut-back asphalt RC-70 or RC-250, meeting requirements of ODOT Specifications Subsection 708.03.
- B. Prime Coat: MC-30 or MC-70 asphalt meeting requirements of ODOT Specifications Subsection 708.03.

### **2.03 MIXING ASPHALTIC CONCRETE MATERIALS**

- A. Provide hot plant mixed asphalt concrete paving materials.
  - 1. Temperature leaving the plant: 290°F minimum, 320° F maximum.
  - 2. Temperature at time of placing: 280°F minimum.

### **2.04 MARKING PAINT**

- A. Locations -
  - 1. Parking Stall striping and drives: As shown on the Drawings.
- B. Acceptable Products / Manufacturers -
  - 1. Traffic: Line Traffic Marking Paint. Refer to Specification Section 32 1317 – Pavement Marking.
- C. Colors -
  - 1. White parking striping unless otherwise noted on plans.
  - 2. Handicapped signage colors as shown on Drawings.

### **2.05 HANDICAPPED PARKING SIGNS**

- A. Signs as shown on Drawings. Refer to Specification Section 32 1318 – Traffic & Handicap Parking Signs.

## **PART 3 EXECUTION**

### **3.01 SURFACE CONDITIONS**

- A. Examine the areas and conditions under which work of this Section will be performed. Correct conditions detrimental to timely and proper completion of the Work. Do not proceed until unsatisfactory conditions are corrected.

### **3.02 FINISH ELEVATIONS AND LINES**

- A. Comply with pertinent provisions of Division I Specifications.
- B. Establish and identify required lines, levels, contours and datum.

### **3.03 PROTECTION**

- A. Provide flagmen, barricades, warning signs, and warning lights, as required.
- B. Maintain access to adjacent areas at all times.

### **3.04 PREPARATION**

- A. Refer to Section 31 2000 for excavation, rough grading and filling.

### **3.05 ASPHALT CONCRETE PAVING**

- A. Construct in compliance with ODOT Specifications Section 411, with additions or exceptions as specified.
- B. Clean substrates of dirt, oils, and other contaminants detrimental to bonding, appearance and performance of installed paving.
- C. Apply the specified prime coat, and tack coat where required, and allow to dry.
- D. Receipt of Asphalt Concrete Materials:
  - 1. Do not accept material unless it is covered with a tarpaulin until unloaded, and unless the material has a temperature of not less than 280°F.
  - 2. Do not commence placement of asphalt concrete materials when the atmospheric temperature is below 45°F, nor during fog, rain or other unsuitable conditions.
- E. Placement:
  - 1. Place in 10-ft. minimum width strips, unless otherwise approved or required for areas being paved.
  - 2. Spreading:
    - a. Spread material in a manner which requires the least handling. Use a mechanical spreader for lay-down, except in inaccessible or small areas.
    - b. The mechanical spreader shall be adjusted and the speed regulated so that the surface of the course being laid will be smooth and continuous without tears and pulls, and of such depth that, when compacted, the surface will conform to the cross section indicated.
    - c. Where thickness of finished paving will be 3" or less, spread in one layer.
  - 3. Place inaccessible and small areas by hand.
  - 4. Place each course to required grade, cross section and compacted thickness.
  - 5. After first strip or course has been placed, rolled, and compacted, place succeeding courses or strips and extend rolling and compaction to overlap previous sections.
    - a. The screed of the mechanical spreader shall overlap the previously placed strip 2 to 3 inches and be sufficiently high so that compaction produces a smooth, dense joint.
    - b. Mixture placed on the edge of a previously placed strip by the mechanical spreader shall be pushed back to the edge of the strip by use of a lute.
    - c. Excess mixture shall be removed and wasted.
  - 6. Complete base courses before placing surface course.
  - 7. Construct each section of each base or surface course to match adjacent sections in texture, density and smoothness. Make joints between old and new pavements and between successive days work to ensure continuous bond between adjoining work; clean contact surfaces and apply tack coat.
- F. Rolling: Roll each course as follows:
  - 1. Start when mixture will bear roller weight without excessive displacement. Compact areas inaccessible to rollers with hot hand tampers or vibrating plate compactors.
  - 2. Initial (Breakdown) Rolling: Accomplish immediately following rolling of joints and outside edge. Check surface after rolling and repair displaced areas by loosening and filling with hot material, if required.
  - 3. Second Rolling: Perform as soon as possible following breakdown rolling, while mixture is hot. Continue rolling until mixture has been thoroughly compacted.
  - 4. Finish Rolling: Perform while mixture is still warm enough for removal of roller marks. Continue rolling until roller marks are eliminated and until courses have attained maximum density.
  - 5. Compact each course to a mat density of 95%.

### **3.06 PRIME COAT**

- A. Apply to subgrade at 0.10 to 0.45 gallon rate per square yard, to penetrate and seal, but not flood, surface, in compliance with requirements of ODOT Specifications Section 408 and at temperature specified in ODOT Specifications Subsection 708.03.
- B. Allow to cure and dry as long as necessary to attain penetration and evaporation of volatile.

- C. Do not apply when temperature is below 45°F. in shade, or when weather conditions prevent proper construction of prime coat.

### **3.07 TACK COAT**

- A. Apply to contact surfaces of asphalt concrete base course, abutting existing asphalt concrete paving, and to contact surfaces of new and existing concrete which abuts or projects into asphalt concrete paving, in compliance with requirements of ODOT Specifications Section 407 and at temperature specified in ODOT Specifications Subsection 708.03.
- B. Distribute at 0.10 gallon per square yard of surface maximum rate.
- C. Do not apply during wet or cold weather, after sunset, or to wet surfaces.

### **3.08 PATCHING**

- A. Remove and replace defective areas and areas mixed with foreign materials; cut-out areas and fill with fresh hot asphalt concrete and compact, by rolling, to maximum density and smoothness.

### **3.09 FINISH**

- A. After final rolling, no traffic shall be permitted on paving until it has cooled and hardened and in no case less than 6 hours.
- B. The paved areas shall drain as indicated; no bumps or "bird baths" will be accepted.
- C. The surface shall be clean and free of dirt or debris ready for traffic painting as specified after a minimum 30 day curing period.

### **3.10 DISPOSAL**

- A. Transport debris and excess material from site and legally dispose of them.

### **3.11 SAMPLING AND TESTING**

- A. Secure the testing laboratory's inspection and approval of paving before subsequent construction is permitted.
- B. Field Quality Control:
  - 1. Sampling of asphalt concrete paving mixtures shall be done in accordance with ASTM D 979.
  - 2. Asphalt Extraction: One test per 2,000 square yards of each course placed in accordance with ASTM D 2172.
  - 3. Aggregate Gradation: One test per 2,000 square yards of each course placed in accordance with AASHTO T 30.
  - 4. In-Place Density:
    - a. The degree of pavement compaction shall be determined in accordance with AASHTO T 230.
    - b. Three tests shall be made at randomly selected locations for the first 1,000 square yards, or fraction thereof, of each course of mix placed on the job. These tests shall determine the sufficiency of the equipment and methods for placing and compacting the asphalt concrete paving mixture.
    - c. After the first set of tests, one test shall be made at a randomly selected location for each 1,000 square yards, or fraction thereof, of each course of mix placed.
    - d. Acceptance of the compacted mixture with respect to density shall be based on relative density (specific gravity). The compacted base and surface will be accepted when the average of any three consecutive specific gravity determinations is equal to or greater than 95% of the theoretical maximum specific gravity and when no individual determination is lower than 93%.
- C. Thickness: Do not exceed following tolerances from elevations shown on drawings:
  - 1. Base Courses: Plus or minus 3/8".
  - 2. Surface Course: Plus or minus 1/4".
- D. Surface Smoothness: Check longitudinally and transversely with 12-ft. straightedge placed parallel to and perpendicular to paving centerline at directed intervals along surface. Do not exceed following tolerances from straightedge:
  - 1. Base Courses: Plus or minus 1/4".
  - 2. Surface Course: Plus or minus 1/4".

- E. Flood Test: Prior to striping, perform a flood test in the presence of the Engineer.
  - 1. Flood the entire asphalt concrete paved area with water by use of a tank truck or hoses.
  - 2. If a depression is found where water ponds to a depth of more than 1/8" in six feet, fill or otherwise correct to provide proper drainage.
  - 3. Feather and smooth the edges of fill so that the joint between fill and original surface is invisible.
- F. Repair, or remove and replace, unacceptable work as directed and at no additional costs.

### **3.12 PROTECTION**

- A. Erect barricades to protect paving from vehicular traffic until mixture has cooled and attained its maximum degree of hardness.

### **3.13 MARKING PAINT**

- A. Parking stall and drives stripe as shown on Drawings.

### **3.14 HANDICAPPED PARKING SIGNS**

- A. Install signs as shown on Drawings.

**END OF SECTION**

## SECTION 32 1313

### PORTLAND CEMENT CONCRETE PAVING

#### PART 1 GENERAL

##### 1.01 RELATED DOCUMENTS

- A. Drawings and general provisions of the Contract, including The City of Chickasha Standard Specifications for the Construction of Public Improvements.

##### 1.02 SECTION INCLUDES

- A. Portland cement concrete paving.

##### 1.03 SUBMITTALS

- A. Comply with pertinent provisions of Division I Specifications.
- B. Joint Layout: Submit joint layout if proposed jointing differs from layout shown on the Drawings.

##### 1.04 QUALITY ASSURANCE

- A. Use adequate numbers of skilled workmen who are thoroughly trained and experienced in the necessary crafts and who are completely familiar with the specified requirements and the methods for proper performance of the work of this Section.
- B. Equipment: Type approved prior to use, for capability of equipment to perform acceptable work.
- C. Do not commence placement of concrete until mix designs have been reviewed and approved by the Engineer and all governmental agencies having jurisdiction, and until copies of the approved mix designs are at the job site and the batch plant.
- D. Provide access for, and cooperate with, the inspector and testing laboratory.
- E. Testing Services: By independent commercial testing laboratory employed and paid by Contractor, acceptable to Engineer.
- F. Reference Standards: Referenced portions of Oklahoma Department of Transportation "Standard Specifications for Highway Construction", Latest Edition as amended to date, as referenced herein as "ODOT Specifications".

##### 1.05 PROJECT CONDITIONS

- A. Confine equipment, apparatus, materials, storage, and operations of workers to limits provided by law, ordinances, permits, contract documents, and as directed.

#### PART 2 PRODUCTS

##### 2.01 GENERAL

- A. Provide forms, reinforcement, concrete, curing, and other materials as specified in ODOT Specifications Section 414, "Portland Cement Concrete Pavement", and as required in this Section.
- B. Where conflicts occur between the requirements of ODOT Section 414 and this Section, requirements of this Section shall take precedence.
- C. Concrete: 28-day compressive strength of 3500 psi.

##### 2.02 BAR MATS, DOWELS, AND TIE BARS

- A. Bar Mats: Deformed steel bar mats conforming to ASTM A 184, grade 40 or 60.
- B. Dowels: Plain steel bars conforming to ASTM A 615, grade 40 or 60.
- C. Tie Bars: Deformed steel bars conforming to ASTM A 615, grade 40 or 60; except that grade 60 bars shall not be used for bars that are bent and straightened during construction.

##### 2.03 JOINT FILLER

- A. Expansion Joints: Filler shall be preformed materials conforming to ASTM D 1751 or ASTM D 1752.

- B. Contraction Joints: Contraction joint inserts shall have sufficient stiffness to permit placement in plastic concrete without undue deviation from a straight line. Insert materials shall conform to ASTM D 2628.

## **2.04 EPOXY RESIN**

- A. Two-component materials conforming to the requirements of ASTM C 881, class as appropriate for each application temperature to be encountered.
- B. Materials for bonding freshly mixed portland cement concrete or mortar or freshly mixed epoxy resin concrete or mortar to hardened concrete shall be Type II materials, grade as approved by the Engineer.
- C. Materials for use as patching materials for complete filling of spalls, wide cracks, and other voids; for use for embedding dowels and anchor bolts; and for use as a binder in preparing epoxy resin mortars and concretes shall be Type III materials.
  - 1. Bond strength at 14 days (moist cure) shall be at least 1000 psi.
  - 2. Volatile content, cured system, shall not exceed 3%.
  - 3. Grade shall be as approved by the Engineer except that Grade 3 shall be used for embedding dowels in hardened concrete.

## **2.05 JOINT SEALANT**

- A. Seal joints with silicone sealant, ODOT Section 701.08.
- B. Separating and Blocking Medium: Separating and blocking material used to seal off the lower portion of the joint shall be a readily compressible, nonshrinkable rope plastic or rubber not reactive with the sealant. The separating and blocking medium shall not soften or melt at pouring temperature of the sealant.
- C. Bond Breaker Tape: The bond breaker medium shall be a flexible, nonshrinkable, nonabsorptive, and nonreactive adhesive-backed tape. The bond breaker tape shall be 1/8-inch wider than the nominal width of the joint.

## **2.06 OTHER MATERIALS**

- A. Provide other materials, not specifically described but required for a complete and proper installation, as selected by the Contractor subject to the approval of the Engineer.

## **PART 3 EXECUTION**

### **3.01 SURFACE CONDITIONS**

- A. Examine the areas and conditions under which work of this Section will be performed. Correct conditions detrimental to timely and proper completion of the Work. Do not proceed until unsatisfactory conditions are corrected.

### **3.02 PREPARATION**

- A. Repair and recompact to 95% of Standard Proctor Density subgrade disturbed and not satisfactory or subgrade softened to extent that it does not have specified density and proper moisture content.
- B. Shape to line, grade, and cross-section.

### **3.03 SETTING FORMS**

- A. Comply with requirements of ODOT Specification Section 414 and the following:
  - 1. Install sufficient quantity to allow continuous progress of work, and so forms can remain in place for 24 hours minimum after concrete placement.
  - 2. Check completed formwork for grade and alignment, do not exceed following tolerances:
    - a. Top of Forms: Not more than 1/8" in 10'-0".
    - b. Vertical Face: Longitudinal axis, not more than 1/4" in 10'-0".

### **3.04 PLACING REINFORCEMENT**

- A. Install in compliance with the requirements of ODOT Specification Section 414.

### **3.05 INSTALLING DOWELS AND TIE BARS**

- A. Install in compliance with the requirements of ODOT Specification Section 414.
  - 1. When bending tie bars, the minimum radius of curvature recommended for the particular grade of steel cited in the appropriate standard shall be used. Before placement of the adjoining lane, the tie bars will be straightened.
- B. Fixed-Form Installation:
  - 1. Fixed-form installation of dowels and tie bars shall be by the bonded-in-place method.
  - 2. Tie bars and dowels shall be prepared and placed across joints where indicated, correctly aligned, and securely held in the proper horizontal and vertical position during placing and finishing operations.
  - 3. Dowels in longitudinal and transverse construction joints shall be held securely in place parallel to the surface, as indicated, by means of devices fastened to the form.
  - 4. Dowels in expansion joints and tie bars and dowels installed within the paving lane shall be held securely in place, as indicated, by means of rigid metal frames or basket assemblies of approved type.
  - 5. Dowels in longitudinal joints shall be omitted when the center of the dowel is located within a horizontal distance from a transverse joint equal to one-fourth of the slab thickness.
- C. Slipform Installation:
  - 1. Dowels in longitudinal construction joints shall be placed by bonding the dowels into holes drilled into the hardened concrete.
    - a. Holes approximately 1/8-inch greater in diameter than the dowels shall be drilled with rotary-type core drills that must be held securely in place to drill perpendicularly into the vertical face of the pavement slab.
    - b. Dowels shall be bonded in the drilled holes using an epoxy resin material.
    - c. Installation procedures shall be adequate to ensure that the area around dowels is completely filled with epoxy grout.
  - 2. Dowels in expansion and contraction joints installed within the paving lane shall be held securely in place by means of rigid metal frames or basket assemblies of the type used in the method described in requirements for fixed-form installation.
  - 3. Tie bars installed within the paving lane shall be held securely in place by means of rigid metal frames or basket assemblies as required by fixed-form installation.
  - 4. When tie bars are specified in longitudinal construction joints, bent tie bars shall be installed in front of the paver by insertion into the unconsolidated plastic concrete through a 26-gauge metal keyway liner.
    - a. Tie bars shall not be installed in the plastic concrete after the concrete has been consolidated and the cross section formed. Tie bars shall not be installed in preformed holes in hardened concrete.
    - b. The keyway liner shall remain in place and become part of the joint.

### **3.06 PLACING CONCRETE**

- A. General:
  - 1. Construct in one course in conformity with lines, grade, thickness, and typical sections shown on the Drawings and in compliance with the requirements of ODOT Specifications Section 414.
  - 2. Place concrete between stationary forms or construct to the desired cross section using slipform pavers.
  - 3. Concrete placement shall be continuous and at a uniform rate without unscheduled stops except for equipment failure or other emergencies.
- B. Slipform Method:
  - 1. Slipform paver shall be self-propelled, automatically controlled, crawler-mounted, and capable of spreading, consolidating, and shaping the plastic concrete to the desired cross section in one pass.
  - 2. Paver shall be capable of finishing the surface and edges so that a minimum amount of hand finishing is required, and shall have sufficient weight and power to handle the amount of concrete required for the full-lane width as specified.
  - 3. Horizontal and vertical alignment shall be referenced to a taut wire or string line.
  - 4. Vibrators or tamping elements shall be automatically controlled so that they shall be stopped as forward motion ceases.

5. When the paver approaches a header at the end of a paving lane, a sufficient amount of concrete shall be maintained ahead of the paver to allow a roll of concrete to spill over the header.
- C. Spreading:
1. Spreading shall be by machine method. Hand spreading will be permitted only where required for odd widths or shapes of slabs.
  2. Mechanical spreaders shall be designed and operated to distribute the plastic concrete uniformly across the full width of the paving lane.

### 3.07 CONSOLIDATION

- A. Consolidate concrete immediately after placing in compliance with the requirements of ODOT Specifications Section 414.
- B. Use internal vibrating units or a vibratory finishing machine.
- C. Internal Vibrating Units:
1. Number of units and the power of each unit shall be adequate to properly consolidate the concrete with the vibration spacing used.
  2. Vibrating unit shall be mounted on a frame or on the paver and equipped with suitable controls so that all vibrators may be operated at any desired depth within the slab or completely withdrawn from the concrete, as required.
  3. Spacing of vibrating units that extend into the slab at intervals across the paving lane shall be as necessary to properly consolidate the concrete, but the clear distance between the units shall not exceed 30 inches.
  4. Outside elements shall be approximately 1 foot from the edge of the slab.
- D. Vibratory Finishing Machine:
1. Power operated approved type.
  2. Vibratory template shall be two feet longer than slab width and designed to vibrate and consolidate freshly struck off concrete to required grade. Template shall be steel, shaped to crown or slope of pavement, with a face at least 3½" in width.

### 3.08 FINISHING

- A. General:
1. Finish pavement in compliance with the requirements of ODOT Specifications Section 414 and this Section.
  2. Finishing shall be by the machine method except where otherwise indicated; the hand method will be permitted on odd slab widths or shapes and in event of breakdown of the mechanical equipment, to finish concrete.
  3. Excessive manipulation that brings mortar and water in excess of 1/8-inch thick to the surface will not be permitted, and any equipment that does not produce the required compaction and surface finish will be considered unsatisfactory.
- B. Machine Finishing with Fixed Forms:
1. Finishing machine shall be designed and operated to strike off, screed, and consolidate the concrete.
  2. Finishing machine shall make as many trips over each area of pavement as necessary to compact the concrete and produce a surface of uniform texture, true to grade. Water shall not be added to the concrete used to fill low spots or to facilitate finishing operations.
  3. After completion of screeding, the mechanical float shall be operated to smooth and finish the pavement to grade. The float shall be operated so as to maintain contact with the surface at all times.
- C. Finishing by Slipform Method:
1. Slipform paver shall be capable of finishing the surface and edges so that only a minimum of additional work is necessary.
  2. A self-propelled pipe float may be used if the Contractor desires, while the concrete is still plastic, to remove minor irregularities and score marks. Pipe floating will be accomplished as soon as possible and discontinued immediately after a uniform surface appearance is achieved.



3. Concrete slurry permitted to run down the vertical edges of the slipped concrete will be removed by hand, using stiff brushes or other approved scrapers.
  4. Wood or metal forms shall be available for use in repairing edges that slough excessively.
- D. Hand Finishing:
1. The entire surface shall be tamped, and the tamping operation continued until the required compaction and reduction of internal and surface voids are accomplished.
  2. Immediately following the final tamping of the surface, the pavement shall be floated longitudinally from bridges resting on the side forms and spanning but not touching the concrete.
  3. If necessary, additional concrete shall be placed and screeded, and the float operated until a satisfactory surface has been produced.
- E. Texturing:
1. Before the surface sheen has disappeared and before the concrete becomes nonplastic, the surface of the pavement shall be given a texture by one of the following methods:
  2. Burlap-Drag Texture:
    - a. Surface texture shall be applied by dragging the surface of the pavement, in the direction of the concrete placement, with an approved multiple-ply burlap drag at least 3 feet in width and equal in length to the width of slab.
    - b. The dragging shall produce a uniform finished surface having a fine sandy texture without disfiguring marks.
  3. Wire Comb Texture:
    - a. Surface texture shall be applied using an approved wire comb.
    - b. The wire comb shall be operated mechanically with the length of the comb parallel to the pavement center line.
    - c. Successive passes of the comb shall be overlapped the minimum necessary to obtain a continuous and uniformly textured surface.
    - d. Texturing shall be completed before the concrete has dried to the point where the surface and edges will be unduly torn, but after drying has progressed to the point where the serrations will not close up.
    - e. Serrations shall be 1/16- to 3/16-inch deep, 1/16- to 1/8-inch wide, and spaced 1/4- to 1/2 inch apart.
  4. Broom Texturing:
    - a. Surface texture shall be applied using an approved hand or mechanical stiff bristle broom of a type that will produce uniform corrugations.
    - b. Broom shall be operated with the length of the broom parallel to the pavement center line.
    - c. Successive passes of the broom shall be overlapped the minimum necessary to obtain a uniformly textured surface.
    - d. Brooms shall be washed thoroughly and dried at frequent intervals during use.
    - e. Brooming shall be completed before the concrete has dried to the point where the surface will be unduly torn or roughened, but after drying has progressed enough so that the mortar will not flow and attenuate the sharpness of the corrugations.
    - f. Corrugations shall be uniform in appearance and approximately 1/16-inch in depth but not more than 1/8-inch in depth.
- F. Edging:
1. After texturing has been completed, the edge of slabs along the forms, along the edges of slipformed lanes and at the joints shall be carefully finished with an edging tool to form a smooth rounded surface of the required radius.
  2. Tool marks shall be eliminated, and the edges shall be smooth and true to line.

### 3.09 JOINTS

- A. General:
1. Joints shall be of the type and location shown on the Drawings. Where not shown, contraction joints shall divide the pavement into equal size squares or into equal size rectangles whose longest side is no more than 1.25 times the shortest side. The maximum length of any side shall be 15 feet.
  2. Joints shall conform to the details indicated and shall be perpendicular to the finished grade of the pavement.

3. Transverse expansion and contraction joints shall be straight and continuous from edge to edge of the pavement.
  4. Place transverse joints to align with existing joints where new paving joins existing paving, unless otherwise shown.
- B. Longitudinal Construction Joints:
1. When the concrete is placed using stationary forms, metal forms securely fastened to the concrete form shall be used to form the keyway in the plastic concrete.
  2. When the concrete is placed using slipform pavers, the keyway shall be formed in the plastic concrete by means of metal forms permanently attached to the side forms or by means of preformed metal keyway liners, which are inserted during the slipform operations and shall be left in place.
  3. Longitudinal construction joints shall be edged and subsequently sawed to provide a groove at the top conforming to the details and dimensions indicated.
- C. Transverse Construction Joints:
1. Transverse construction joints shall be installed at the end of each day's placing operations and at any other points within a paving lane when concrete placement is interrupted for 30 minutes or longer. These joints shall be located at a planned joint.
  2. Transverse construction joints shall be doweled, one-half of each dowel painted and oiled to permit movement at the joint.
  3. Transverse construction joints shall be edged and subsequently sawed to provide a groove at the top conforming to the details and dimensions indicated.
  4. When using slipform pavers, transverse construction joints shall be constructed by utilizing headers, hand placement, and finishing techniques.
- D. Expansion Joints:
1. Expansion joints shall be formed by means of a preformed filler material.
  2. Filler shall be securely held in position by means of approved metal supports, which shall remain in the pavement.
  3. A removable metal-channel cap bar shall be used to hold the parts of the joint in proper position and protect the filler from damage during concreting operations. The cap bar shall be removable without damage to the pavement to provide a space for sealing of the joint.
  4. Expansion joints shall be formed about structures and features that project through, into, or against the pavement, using joint filler of the type, thickness, and width indicated, and shall be installed in such manner as to form a complete, uniform separation between the structure and the pavement.
- E. Contraction Joints:
1. Transverse and longitudinal contraction joints shall be of the weakened-plane or dummy type and shall be constructed as indicated, with a depth equal to 1/4 slab thickness unless otherwise detailed.
  2. Longitudinal contraction joints shall be constructed by sawing a groove in the hardened concrete in conformance with requirements for sawed joints unless otherwise approved.
  3. Transverse contraction joints shall be constructed in conformance with requirements for sawed joints or insert-type contraction joints, unless otherwise approved.
- F. Sawed Joints:
1. Sawed joints shall be constructed by sawing a groove in the concrete with a 1/8-inch blade to the full depth as indicated.
  2. After expiration of the curing period, the upper portion of the groove shall be widened by sawing to the width and depth indicated.
  3. Sawing of the joints shall commence as soon as the concrete has hardened sufficiently to permit cutting the concrete without chipping, spalling, or tearing.
  4. Saw cut shall not vary more than 1/2 inch from the true joint alignment.
  5. Joint shall not be sawed if a crack has occurred near the planned joint location or when a crack develops ahead of the saw cut.
  6. Immediately after the joint is sawed, the saw cut and adjacent concrete surface shall be thoroughly flushed with water until all waste from sawing is removed from the joint.
  7. Membrane-cured surface damaged during the sawing operations shall be resprayed as soon as the surface becomes dry.

### 3.10 CURING

- A. Cure finished pavement in compliance with the requirements of ODOT Specifications Section 414.

### 3.11 SEALING JOINTS

- A. Seal joints in accordance to ODOT Specifications
- B. Sandblast Cleaning:
  - 1. Joint faces and the pavement surfaces extending about ½ inch from the joint edges shall be sandblast cleaned.
  - 2. A multiple-pass technique shall be used until the surfaces are free of saw-cutting fines that might prevent bonding of the sealant to the concrete.
  - 3. After final cleaning and immediately prior to sealing, the joints shall be blown out with compressed air and left completely free of sand and water.
- C. Separating and Blocking Media:
  - 1. Lower portion of the groove shall be sealed off to prevent entrance of the sealant below the depth specified.
  - 2. The blocking medium shall not be stretched during insertion in the joint.
- D. Bond Breaker Tape:
  - 1. Bond breaker tape shall be installed on top of expansion joint material.
  - 2. The tape shall be securely bonded so it will not float up into the new sealant.
- E. Sealing:
  - 1. Joints shall be sealed immediately following final cleaning of the joint walls and following the placement of separating and blocking media.
  - 2. Joints shall be filled from the bottom up to within 1/8-inch of the pavement surface using specified equipment.
  - 3. Excess or spilled sealant shall be removed from the pavement by approved methods and shall be discarded.
  - 4. Traffic shall not be permitted over newly sealed pavement until authorized by the Engineer.
  - 5. When a primer is supplied by the manufacturer of a sealant, it shall be applied evenly to the joint faces in accordance with the manufacturer's recommendations.

### 3.12 INTEGRAL CURBS

- A. Integral curbs shall be constructed to dimensions and at locations indicated. Maximum nominal size of the coarse aggregate for curb construction shall be 1½ inches.
- B. Forms for Integral Curbs:
  - 1. Forms for curbs shall be of similar material to that used for pavement.
  - 2. Outside form shall be of a depth equal to the combined depth of the integral curb and the pavement slab.
  - 3. Inside curb-face form shall have a batter from the top of the curb to the finished pavement surface as indicated.
  - 4. Inside curb form shall be securely fastened to and supported by the outside form. Fastenings shall not obstruct the satisfactory finishing and edging of the top of the curb and shall permit early removal of the face form.
- C. Placing:
  - 1. Concrete curb shall be placed as soon as practical after the slab is placed, but in no case shall the time between the placing of the slab and the placing of the curb exceed 45 minutes.
  - 2. Concrete shall be thoroughly spaded or vibrated until well compacted and until a good bond is obtained between the curb and the slab.
- D. Joints:
  - 1. Joints shall be of the type and construction specified for the pavement slab on which the curb is placed.
  - 2. Pavement joints shall extend through the curb except that horizontal dowels will not be required between joints in the curb.
- E. Finishing Curbs:

1. Top of the curb shall be floated to compact the concrete thoroughly and produce a smooth even surface.
2. Edges of the curb and joints shall be rounded by using appropriate edging tools.
3. Vertical edges of joints shall be dressed when the curb form is removed.
4. While the concrete is green, the top and face of the curb shall be finished by rubbing the surface with a wood or concrete rubbing block and water until all blemishes, form marks, and tool marks are removed.
5. Rubbed surface shall then be brushed with a fine-textured brush to obtain a uniform sandy texture, free from humps, sags, and other irregularities.
6. Top and face of the curb shall not vary more than 1/8-inch from the edge of a 10-foot straightedge, except at grade changes or curves.

### **3.13 CONCRETE PAVING REPAIRS**

- A. Repair concrete in compliance with the requirements of ODOT Specifications Section 414 and this Section.
- B. Defective concrete shall be removed and replaced at the Contractor's expense if, in the opinion of the Engineer, it cannot be adequately repaired.
- C. Removal and Replacement of Defective Concrete:
  1. In no case shall the removal and replacement of concrete result in a slab less than a full paving lane width or a joint less than 10 feet from a regularly scheduled transverse joint.
  2. Defective concrete shall be removed carefully so that the adjacent pavement will not be damaged and the existing keys or dowels at the joints will be left intact.
  3. When a portion of the unfractured slab is replaced, a saw cut 4-inches deep shall be made transversely across the slab in the required location, and the concrete shall be removed to provide an essentially vertical face in the remaining portion of the slab.
  4. Prior to placement of the fresh concrete, the face of the slab shall be cleaned of debris and loose concrete, and then thoroughly coated with epoxy-resin.
  5. Strips of polyethylene sheeting shall be placed on the vertical joint faces of adjacent slabs at the juncture with the slab to be patched as a bond-breaking medium.
  6. Placement of the fresh portland cement concrete shall be accomplished while the epoxy resin is still tacky and in such manner that the grout coating will not be removed.
  7. Longitudinal and transverse joints of the replaced slab or portion thereof shall be constructed as indicated and the joints sealed.

### **3.14 PROTECTION**

- A. Beginning immediately after placement, protect concrete from mechanical injury.
- B. Protect concrete from physical damage or reduced strength due to weather extremes during mixing, placing and curing.

### **3.15 DISPOSAL**

- A. Transport debris and excess material from site and legally dispose of them.

**END OF SECTION**

## SECTION 32 1314

### CONCRETE SIDEWALKS, CURBS AND GUTTERS

#### PART 1 GENERAL

##### 1.01 RELATED DOCUMENTS

- A. Drawings and general provisions of the Contract, including The City of Chickasha Standard Specifications for the Construction of Public Improvements.

##### 1.02 SECTION INCLUDES

- A. Portland cement concrete sidewalks.
- B. Portland cement curbs and gutters.

##### 1.03 RELATED SECTIONS

- A. Section 31 2000 – Earth Moving.
- B. Section 32 1313 – Portland Cement Concrete Paving.

##### 1.04 SUBMITTALS

- A. Joint Layout: Submit joint layout if proposed jointing differs from layout shown on the Drawings.

##### 1.05 QUALITY ASSURANCE

- A. Use adequate numbers of skilled workmen who are thoroughly trained and experienced in the necessary crafts and who are completely familiar with the specified requirements and the methods for proper performance of the work of this Section.
- B. Equipment: Type approved prior to use, for capability of equipment to perform acceptable work.
- C. Do not commence placement of concrete until mix designs have been reviewed and approved by the Engineer and all governmental agencies having jurisdiction, and until copies of the approved mix designs are at the job site and the batch plant.
- D. Provide access for, and cooperate with, the inspector and testing laboratory.
- E. Testing Services: By independent commercial testing laboratory employed and paid by Contractor, acceptable to Engineer.
- F. Referenced Standards: Referenced portions of Oklahoma Department of Transportation "Standard Specifications for Highway Construction," Latest Edition as amended to date, as referenced herein as "ODOT Specifications".

##### 1.06 PROJECT CONDITIONS

- A. Confine equipment, apparatus, materials, storage, and operations of workers to limits provided by law, ordinances, permits, contract documents, and as directed.
- B. Coordination: Coordinate this work with the work of other Sections to avoid any delay or interference with other work.

#### PART 2 PRODUCTS

##### 2.01 GENERAL

- A. Provide forms, reinforcement, concrete, curing, and other materials as specified in ODOT Specifications Section 609 and 610 and as required in this Section.
- B. Where conflicts occur between the requirements of ODOT Specifications Section 609 and 610 and this Section, requirements of this Section shall take precedence.
- C. Concrete: 28-day compressive strength of 3,500 psi.

## **2.02 FORMS**

- A. Use either steel or wood. Use flexible spring-steel forms or laminated boards to form radius bends as required.
- B. The condition and stability of the forms shall produce a sidewalk, concrete curb, or concrete curb and gutter that will not deviate more than 1/4 inch in 10 feet in either grade or alignment.
- C. Sidewalk forms shall be of a height equal to the full depth of the finished sidewalk.
- D. Curb and Gutter Forms:
  - 1. Curb and gutter outside forms shall have a height equal to the full depth of the curb or gutter. The inside form of curb shall have batter as indicated and shall be securely fastened to and supported by the outside form.
  - 2. Rigid forms shall be provided for curb returns, except that benders or thin plank forms may be used for curb or curb returns with a radius of 10 feet or more, where grade changes occur in the return, or where the central angle is such that a rigid form with a central angle of 90° cannot be used. Back forms for curb returns may be made of 1½ inch benders, for the full height of the curb, cleated together.

## **2.03 DOWELS AND TIE BARS**

- A. Dowels: Plain steel bars conforming to ASTM A 615, grade 40 or 60.
- B. Tie Bars: Deformed steel bars conforming to ASTM A 615, grade 40 or 60.

## **2.04 JOINT MATERIAL**

- A. Expansion Joints:
  - 1. Non-sealed joints: Filler premolded bituminous type conforming to ASTM D1751.
  - 2. Sealed joints: Silicone Sealant ODOT Section 701.08.
- B. Joint Sealer: Silicone Sealant ODOT Section 701.08.

## **2.05 EPOXY RESIN**

- A. Two-component materials conforming to the requirements of ASTM C 881, class as appropriate for each application temperature to be encountered.
- B. Materials for bonding freshly mixed Portland cement concrete or mortar or freshly mixed epoxy resin concrete or mortar to hardened concrete shall be Type II materials, grade as approved by the Engineer.
- C. Materials for use as patching materials for complete filling of spalls, wide cracks, and other voids; for use for embedding dowels and anchor bolts; and for use as a binder in preparing epoxy resin mortars and concretes shall be Type III materials.
  - 1. Bond strength at 14 days (moist cure) shall be at least 1000 psi.
  - 2. Volatile content, cured system, shall not exceed 3%.
  - 3. Grade shall be as approved by the Engineer except that Grade 3 shall be used for embedding dowels in hardened concrete.

## **2.06 OTHER MATERIALS**

- A. Provide other materials, not specifically described but required for a complete and proper installation, as selected by the Contractor subject to the approval of the Engineer.

## **PART 3 EXECUTION**

### **3.01 SURFACE CONDITIONS**

- A. Examine the areas and conditions under which work of this Section will be performed. Correct conditions detrimental to timely and proper completion of the Work. Do not proceed until unsatisfactory conditions are corrected.

### **3.02 SUBGRADE PREPARATION**

- A. Grading:

1. Conform with the requirements specified in Section 31 2000.
  2. Shape to line, grade, and cross-section.
- B. Thoroughly wet the subgrade and then compact with two passes of a 500 pound roller.
- C. Remove yielding material deflecting more than ½" under the specified roller to a depth of not less than 4" below subgrade elevation and replace with an approved granular material compacted as described above.
- D. The subgrade shall be in a moist condition when the concrete is placed. In cold weather prepare and protect the subgrade so as to provide a subgrade free from frost when the concrete is deposited.

### **3.03 SETTING FORMS**

- A. Comply with requirements of ODOT Specifications Section 609 and 610 and the following:
1. Install sufficient quantity of forms to allow continuous progress of the work and so that forms can remain in place at least 24 hours after concrete placement.
  2. Check completed form work for grade and alignment to the following tolerances:
    - a. Top of Form: Not more than 1/8" in 10 feet.
    - b. Vertical Face: Longitudinal axis not more than 1/4" in 10 feet.
- B. The forms on the front of the curb shall be removed not less than 2 hours nor more than 6 hours after the concrete has been placed.

### **3.04 PLACING REINFORCEMENT**

- A. Install in compliance with the requirements of ODOT Specification Section 609 and 610.

### **3.05 INSTALLING DOWELS AND TIE BARS**

- A. General:
1. The portion of each dowel intended to move within the concrete or expansion cap shall be painted. The painted portion shall be wiped clean and coated with a thin even film of lubricating oil before the concrete is placed.
- B. Fixed-Form Installation:
1. Fixed-form installation of dowels and tie bars shall be by the bonded-in-place method.
  2. Dowels and tie bars shall be prepared and placed across joints where indicated, correctly aligned, and securely held in the proper horizontal and vertical position during placing and finishing operations.
  3. Dowels and tie bars in construction and expansion joints shall be held securely in place parallel to the surface, as indicated, by means of devices fastened to the form.
- C. Slipform Installation:
1. Dowels in expansion joints shall be held securely in place by means of rigid metal frames or basket assemblies of approved type.
  2. Dowels and tie bars in construction and expansion joints at the end of a run shall be held securely in place parallel to the surface, as indicated, by means of devices fastened to the end form.

### **3.06 CONCRETE PLACEMENT AND FINISHING**

- A. General: Comply with the requirements of ODOT Specifications Section 609 and 610 for mixing and placing concrete, and as specified herein.
- B. Moisten subgrade as required to reduce suction at the time concrete is placed. Do not place concrete around structures until they have been brought to the required grade and alignment.
- C. Deposit and spread concrete in a continuous operation between transverse joints. If interrupted for more than ½ hour, place a construction joint.

### **3.07 SIDEWALK CONCRETE PLACEMENT AND FINISHING**

- A. Formed Sidewalks:
1. Place concrete in the forms in one layer of such thickness that when consolidated and finished the sidewalks will be of the thickness indicated. After concrete has been placed in the forms,

use a strike-off guided by side forms to bring the surface to proper section to be compacted. Consolidate the concrete with an approved vibrator, and finish the surface to grade with a wood float, bull float, or darby, edged and broom finished.

2. Concrete Finishing:
  - a. After straight edging, when most of the water sheen has disappeared, and just before the concrete hardens, finish the surface to a smooth and uniformly fine granular or sandy texture free of waves, irregularities, or tool marks.
  - b. Produce a scored surface by brooming with a fiber-bristle brush in a direction transverse to that of the traffic.
3. Edge and Joint Finishing:
  - a. Finish all slab edges, including those at formed joints, carefully with an edger having a radius of 1/8 inch. Edge transverse joints before brooming, and use brooming to eliminate the flat surface left by the surface face of the edger.
  - b. Clean corners and edges which have crumbled and areas which lack sufficient mortar for proper finishing and fill solidly with a properly proportioned mortar mixture and then finish.

B. Slip-Formed Sidewalks:

1. Place concrete to the desired section in a single pass.
2. When the paver approaches a header at the end of a paving lane, maintain a sufficient amount of concrete ahead of the paver to allow a roll of concrete to spill over the header. The amount of extra concrete shall be sufficient to prevent the slurry that is formed and carried along ahead of the paver from being deposited adjacent to the header. Bring the spud vibrators on the front of the paver as close to the header as possible before they are lifted. Provide additional consolidation adjacent to the headers by hand-manipulated vibrators.
3. When the slip form paver is operated between or adjacent to previously constructed slabs, make provisions to prevent damage to the previous construction. Transversely oscillating screeds shall be electronically controlled from the previously placed slab to prevent the screed from applying pressure to the existing concrete. When the paver travels on existing pavement, make provisions to prevent damage to the existing pavement.
4. Finished surface at the edges shall not produce an edge slump exceeding 0.25 inch over 85% of the finished work and 100% of the work shall not have an edge slump exceeding 0.75 inch.

C. Surface and Thickness Tolerances:

1. Finished surfaces shall not vary more than 5/16 inch from the testing edge of a 10-foot straightedge.
2. Permissible deficiency in section thickness will be up to 0.25 inch.

### 3.08 CURB AND GUTTER CONCRETE PLACEMENT AND FINISHING

A. Formed Curb and Gutter:

1. Place concrete to the section required in a single lift. Consolidation shall be achieved by using approved mechanical vibrators.
2. Concrete Finishing:
  - a. Float and finish exposed surfaces with a smooth wood float until true to grade and section and uniform in texture. Brush floated surfaces with a fine-hair brush with longitudinal strokes.
  - b. Round edges of the gutter and top of the curb with an edging tool to a radius of 1/2 inch.
  - c. Immediately after removing the front curb form, rub the face of the curb with a wood or concrete rubbing block and water until blemishes, form marks, and tool marks have been removed. Brush the front curb surface, while still wet, in the same manner as the gutter and curb top.
  - d. The top surface of gutter and entrance shall be finished to grade with a wood float.
3. Joint Finishing: Finish curb edges at formed joints as indicated.

B. Curb Forming Machine:

1. Place concrete to the desired section in a single pass.
2. When the paver approaches a header at the end of a paving segment, maintain a sufficient amount of concrete ahead of the paver to allow a roll of concrete to spill over the header. The amount of extra concrete shall be sufficient to prevent the slurry that is formed and carried along ahead of the paver from being deposited adjacent to the header. Bring the paver vibrators as



close to the header as possible before they are lifted. Provide additional consolidation by hand-manipulated vibrators when required.

3. When the curb forming machine is operated between or adjacent to previously constructed curbs, make provisions to prevent damage to the previous construction and the machine.
4. Finished surface at the edges shall not produce an edge slump exceeding 0.25 inch over 85% of the finished work and 100% of the work shall not have an edge slump exceeding 0.75 inch.

C. Surface and Thickness Tolerances:

1. Finished surfaces shall not vary more than 1/4 inch from the testing edge of a 10-foot straightedge.
2. Permissible deficiency in section thickness will be up to 0.25 inch.

### 3.09 SIDEWALK JOINTS

A. Construct sidewalk joints to divide the surface into rectangular areas.

1. Transverse contraction joints shall be spaced at a distance equal to the sidewalk width or 5 feet on centers, whichever is less, and shall be continuous across the slab.
2. Longitudinal contraction joints shall be constructed along the centerline of all sidewalks 10 feet or more in width.
3. Transverse expansion joints shall be installed at sidewalk returns and opposite expansion joints in adjoining curbs. Where the sidewalk is not in contact with the curb, transverse expansion joints shall be installed as indicated. Expansion joints shall be formed about structures and features which project through or into the sidewalk pavement, using joint filler of the type, thickness, and width indicated.

B. Contraction Joints:

1. Contraction joints shall be formed in the fresh concrete by cutting a groove in the top portion of the slab to a depth of at least one-fourth of the sidewalk slab thickness, using a jointer to cut the groove, or by sawing a groove in the hardened concrete with a power-driven saw, unless otherwise approved.
2. Sawed joints shall be constructed by sawing a groove in the concrete with a 1/8-inch blade to the depth indicated.

C. Expansion Joints:

1. Expansion joints shall be formed with 3/8-inch joint filler strips. Joint filler shall be placed with top edge 1/4 inch below the surface and shall be held in place with steel pins or other devices to prevent warping of the filler during floating and finishing.
2. Immediately after finishing operations are completed, joint edges shall be rounded with an edging tool having a radius of 1/8 inch, and concrete over the joint filler shall be removed.
3. At the end of the curing period, expansion joints shall be carefully cleaned and filled with joint sealer. Concrete at the joint shall be surface dry and the atmospheric and pavement temperatures shall be above 50° F at the time of application of joint-sealing materials. Joints shall be filled with sealer flush with the concrete surface in such manner as to minimize spilling on the walk surface. Spilled sealing material shall be removed immediately and the surface of the walk cleaned.

### 3.10 CURB AND GUTTER JOINTS

A. Curb and gutter joints shall be constructed at right angles to the line of curb and gutter.

B. Contraction Joints:

1. Where applicable, contraction joints shall be constructed directly opposite contraction joints in abutting Portland cement concrete pavements and spaced so that monolithic sections between curb returns will not be less than 5 feet nor greater than 15 feet in length.
2. Where curb and gutter does not abut Portland cement concrete pavement, contraction joints shall be spaced so that monolithic sections between curb returns will not be less than 5 feet nor greater than 15 feet in length.
3. Contraction joints shall be constructed by means of 1/8-inch thick separators and of a section conforming to the cross section of the curb and gutter. Separators shall be removed as soon as practicable after concrete has set sufficiently to preserve the width and shape of the joint and prior to finishing.

- C. Expansion Joints:
  - 1. Expansion joints shall be formed by means of preformed expansion joint filler material cut and shaped to the cross section of curb and gutter.
  - 2. Where applicable, expansion joints shall be provided in curb and gutter directly opposite expansion joints of abutting Portland cement concrete pavement, and shall be of the same type and thickness as joints in the pavement.
  - 3. Where curb and gutter does not abut Portland cement concrete pavement, expansion joints at least 3/8 inch in width shall be provided at intervals not exceeding 100 feet.
  - 4. Expansion joints shall be sealed immediately following curing of the concrete or as soon thereafter as weather conditions permit.

### **3.11 CURING AND BACKFILLING**

- A. Curing: Immediately after the finishing operations, the exposed concrete surface shall be cured for 7 days by the mat, impervious sheet, or membrane-curing method.
- B. Backfilling: After curing, debris shall be removed and the areas adjoining shall be backfilled, graded, and compacted to conform to the surrounding area in accordance with the lines and grades indicated.

### **3.12 PROTECTION**

- A. Beginning immediately after placement, protect concrete from mechanical injury.
- B. Protect concrete from physical damage or reduced strength due to weather extremes during mixing, placing and curing.
- C. Repair damaged concrete and clean concrete discolored during construction.
- D. Work that is damaged shall be removed and reconstructed to the entire length between regularly scheduled joints. Refinishing the damaged portion will not be acceptable.

### **3.13 DISPOSAL**

- A. Transport debris and excess material from site and legally dispose of them.

**END OF SECTION**

## SECTION 32 1317

### PAVEMENT MARKING

#### PART 1 GENERAL

##### 1.01 RELATED DOCUMENTS

- A. Drawings and general provisions of the Contract, including The City of Chickasha Standard Specifications for the Construction of Public Improvements.

##### 1.02 SECTION INCLUDES

- A. Pavement marking in the types and arrangements shown.

##### 1.03 RELATED SECTIONS

- A. Section 32 1313 – Portland Cement Concrete Paving.

##### 1.04 SUBMITTALS

- A. Product data: Within 60 calendar days after the Contractor has received the Owner's Notice to Proceed, submit:
  - 1. Materials list of items proposed to be provided under this Section;
  - 2. Manufacturer's specifications and other data needed to prove compliance with the specified requirements;
  - 3. Photographs, scale drawings, or other data acceptable to the Engineer, showing types of graphics proposed to be used.

##### 1.05 QUALITY ASSURANCE

- A. Use adequate numbers of skilled workmen who are thoroughly trained and experienced in the necessary crafts and who are completely familiar with the specified requirements and the methods needed for proper performance of the work of this Section.

#### PART 2 PRODUCTS

##### 2.01 PAVEMENT MARKING PAINT

- A. Provide paint specifically formulated for use as pavement marking in automobile traffic areas, and in the colors selected by the Engineer from standard colors of the approved manufacturer.
- B. Acceptable products:
  - 1. "Traffic Marking Paint" manufactured by Sherwin Williams.
  - 2. "Traffic Paint" manufactured by Aexcel.
  - 3. "Traffic Paint" manufactured by US Specialty Coatings.

##### 2.02 OTHER MATERIALS

- A. Provide other materials, not specifically described but required for a complete and proper installation, as selected by the Contractor subject to the approval of the Engineer.

#### PART 3 EXECUTION

##### 3.01 SURFACE CONDITIONS

- A. Examine the areas and conditions under which work of this Section will be performed. Correct conditions detrimental to timely and proper completion of the Work. Do not proceed until unsatisfactory conditions are corrected.

##### 3.02 APPLICATION

- A. Secure the Engineer's approval of graphics design and layout prior to start of application.

- B. Using proper masking, stencils, and application equipment recommended for the purpose by the manufacturer of the approved paint, apply the approved paint in strict accordance with its manufacturer's recommendations.

### **3.03 PROTECTION**

- A. Provide traffic cones, barricades, and other devices needed to protect the paint until it is sufficiently dry to withstand traffic.

### **3.04 CLEANUP**

- A. When paint is thoroughly dry, visually inspect the entire application, and:
  - 1. Touchup as required to provide clean, straight lines and surfaces throughout.
  - 2. Using a permanently opaque paint identical in color to the surface on which the paint was applied, block out and eliminate all traces of splashed, tracked, and/or spilled pavement marking paint from the background surfaces.

**END OF SECTION**

## SECTION 32 1218

### TRAFFIC AND HANDICAP PARKING SIGNS

#### PART 1 GENERAL

##### 1.01 RELATED DOCUMENTS

- A. Drawings and general provisions of the Contract, including The City of Chickasha Standard Specifications for the Construction of Public Improvements, Special Provisions and Special Provisions – Technical, apply to this Section.

##### 1.02 SECTION INCLUDES

- A. Erect traffic signs.
- B. Erect handicap parking signs.

##### 1.03 RELATED SECTIONS

- A. Section 32 1313 – Portland Cement Concrete Paving.

##### 1.04 SUBMITTALS

- A. Product data: Within 35 calendar days after the Contractor has received the Owner's Notice to Proceed, submit:
  - 1. Materials list of items proposed to be provided under this Section;
  - 2. Manufacturer's specifications and other data needed to prove compliance with the specified requirements;

##### 1.05 QUALITY ASSURANCE

- A. Use adequate numbers of skilled workmen who are thoroughly trained and experienced in the necessary crafts and who are completely familiar with the specified requirements and the methods needed for proper performance of the work of this Section.
- B. Sign Fabricator: Five years experience in fabrication of traffic signs.
- C. Shop Fabrication: Fabricate signs in shop.

##### 1.06 DELIVERY, STORAGE AND HANDLING

- A. Deliver signs to the site in manufacturer's original wrappings and packages clearly labeled with the manufacturer's name, brand name, size, type, message, and related information. Store in a safe, dry, clean, and well ventilated area, protected from damage, soiling, and moisture. Store packages flat. Do not open containers until needed for installation unless verification inspection is required.

#### PART 2 PRODUCTS

##### 2.01 SIGNS

- A. Except where otherwise indicated or specified, all materials shall conform to ANSI D6.1. Unless otherwise shown, all signs shall be "standard" sizes as specified in ANSI D6.1.
- B. Sign Material:
  - 1. Signs shall be constructed of 0.08-inch mill finish aluminum conforming to ASTM B 209, alloy 6061, T 6, degreased and etched.
  - 2. The finish, except the reflective surfacing, shall be baked-enamel finish applied after fabrication.
  - 3. Sign faces shall be fully reflectorized with material conforming to Federal Specification L-S-300, Type I, Class 2, Reflectivity No. 1.
- C. Handicap Symbol Sign and Parking Sign:
  - 1. Parking sign faces shall have a green legend and border with white background.

2. Reserved Parking sign shall also have a white handicap symbol on a blue background and shall be similar to sign R7-8 in ANSI D6.1.

## **2.02 POSTS**

- A. Posts shall be round galvanized steel tubing and shall conform to the indicated details.

## **2.03 APPURTENANCES**

- A. Hardware: Bolts, nuts, washers, and clamps shall be stainless steel. Bolts shall be a minimum of 3/8-inch in diameter.
- B. Concrete: Concrete shall be 3,000 p.s.i.

## **PART 3 EXECUTION**

### **3.01 INSTALLATION**

- A. General:
  1. Except where otherwise indicated or specified, all work shall conform to ANSI D6.1. Signs of the type and size indicated shall be installed in locations shown on the drawings.
  2. Do not install signs until final grading is completed, unless otherwise approved in writing.
- B. Excavation: Drill holes in firm, undisturbed or compacted soil.
  1. Remove loose and foreign materials from sides and bottoms of footing holes. Moisten footing holes before placing concrete.
- C. Posts:
  1. Set in 3,000 psi compressive strength concrete.
  2. Center, align, plumb and brace in footing holes, with post bottoms elevated 3" above bottom of footing hole. Check posts for vertical and top alignment before pouring concrete.
  3. Place concrete in continuous pour; vibrate or tamp for consolidation.
  4. Allow concrete to thoroughly cure before erecting sign.

### **3.02 DISPOSAL**

- A. Transport debris and excess materials from site and legally dispose of it.

**END OF SECTION**

## SECTION 32 9223

### SODDING

#### PART 1 GENERAL

##### 1.01 RELATED DOCUMENTS

- A. Drawings and general provisions of the Contract, including The City of Chickasha Standard Specifications for the Construction of Public Improvements.

##### 1.02 SECTION INCLUDES

- A. Fertilizing.
- B. Sod installation.
- C. Maintenance.

##### 1.03 RELATED SECTIONS

- A. Section 31 2000 – Earth Moving.

##### 1.04 SUBMITTALS

- A. Maintenance Data: Include maintenance instructions, cutting method and maximum grass height; types, application frequency, and recommended coverage of fertilizer.
- B. Certification: Submit sod certification for grass species and location of sod source.

##### 1.05 DEFINITIONS

- A. Weeds: Includes Dandelion, Jimsonweed, Quackgrass, Horsetail, Morning Glory, Rush Grass, Mustard, Lambsquarter, Chickweed, Cress, Crabgrass, Canadian Thistle, Nutgrass, Poison Oak, Grass Blackberry, Tansy Ragwort, Johnson Grass, Poison Ivy, Nut Sedge, Nimble Will, Bindweed, Bent Grass, Wild Garlic, Perennial Sorrel, and Brome Grass.

##### 1.06 QUALITY ASSURANCE

- A. Sod: Minimum age of 18 months, with root development that will support its own weight without tearing, when suspended vertically by holding the upper two corners.
- B. Sod Producer: Company specializing in sod production and harvesting with minimum five-years experience, and certified by the State of Oklahoma.
- C. Installer: Shall have over five-years of documented experience in the scope of work specified.

##### 1.07 REGULATORY REQUIREMENTS

- A. Comply with regulatory agencies for fertilizer and herbicide composition.
- B. Provide certificate of compliance from authority having jurisdiction indicating approval of fertilizer mixture and herbicide mixture.

##### 1.08 DELIVERY, STORAGE, AND HANDLING

- A. Deliver sod on pallets. Protect exposed roots from dehydration.
- B. Do not deliver more sod than can be laid within 24 hours or sod will be rejected.

##### 1.09 JOB CONDITIONS

- A. Proceed with sodding operations after underground sprinkler system has been approved by the Architect.
- B. Work within seasonal limitations of the grass specie.
- C. When detrimental conditions are encountered, notify the Architect.

##### 1.10 MAINTENANCE SERVICE

- A. Maintain sodded areas immediately after placement until Final Acceptance of the project. The lawn shall be well established and exhibit a vigorous growing condition.

#### PART 2 PRODUCT

##### 2.01 MATERIALS

- A. Sod: A cultivated grass sod; 'U-3' Bermuda grass (Cynodon dactylon) with a strong fibrous root

system, Oklahoma grown, free of stones, burned or bare spots; containing no more than 10 weeds per 1,000 square feet.

- B. Topsoil: Refer to Section 31 2000 – Earth Moving.
- C. Fertilizer: Recommended for grass, with 50 percent of the elements derived from organic sources; controlled-release, granular or pellet form, uniform in composition, slow releasing, delivered in fully labeled sealed packages, and shall conform to applicable state or federal regulations, and a composition of the following: nitrogen 10 percent, phosphoric acid 20 percent, and soluble potash 10 percent.
- D. Water: During construction, the domestic water from the Project property will be provided to the Contractor by the Owner. The Contractor shall utilize the water in a conservative manner.
- E. Postemergent Herbicide: As manufactured by LESCO or GORDON'S.

## **2.02 HARVESTING SOD**

- A. Machine cut sod with a minimum soil depth of 3/8".

## **PART 3 EXECUTION**

### **3.01 EXAMINATION**

- A. Examine installation areas. Report unsatisfactory conditions in writing to Architect. Do not proceed until unsatisfactory conditions have been corrected.
  - 1. Verify that prepared topsoil is ready to receive the work of this section.
- B. Starting installation constitutes acceptance of condition or satisfactory for installation of sod by Contractor, who shall correct damage and defects or unsatisfactory work at no additional cost.

### **3.02 PREPARATION OF SUBSOIL**

- A. Comply with Section 31 2000 – Earth Moving. Note: all areas to receive sod, shall be hand raked smooth and leveled prior to installation of sod.
- B. Comply with Section 31 2000 – Earth Moving. Install the erosion control fabric and receive the Architect's approval

### **3.03 FERTILIZING**

- A. Apply fertilizer (10-20-10) at a rate of 2.5 lbs. per 1,000 square feet.
- B. Apply after smooth raking of topsoil and prior to installation of sod.
- C. Apply fertilizer no more than 48 hours before laying sod.
- D. Mix thoroughly into upper 2-inches of imported topsoil.
- E. Lightly water to aid the dissipation of fertilizer.

### **3.04 LAYING SOD**

- A. Moisten prepared surface immediately prior to laying sod.
- B. Lay sod immediately (within 24 hours of harvesting) after delivery to site to prevent deterioration. Sod will be rejected if not installed within this time period. Sod shall be laid so that the top of sod is one (1)-inch below adjacent paving.
- C. Place sod parallel with the adjacent street and building.
- D. Lay sod tight with no open joints visible, and no overlapping; stagger end joints 12-inches minimum. Do not stretch or overlap sod pieces.
- E. Lay smooth. Align with adjoining grass areas and flush with grade.
- F. Place top elevation of sod 1/2-inch below adjoining paving and curbs.
- G. Water sodded areas immediately after installation. Saturate sod to 4-inches of soil. Water by hand or by the irrigation system daily to prevent the root system from drying. Sod shall be kept moist. Dry sod will be rejected and replanted according to this specification.
- H. Once conditions are favorable, roll sodded areas to ensure a good bond between sod and soil and to remove minor depressions and irregularities. Roll sodded areas with a roller not exceeding 250 lbs.

### **3.05 MAINTENANCE**



- A. Maintain the newly sodded grass areas for a minimum of 30-days after installation or until Final Acceptance of the entire project, whichever period is longer. The grass shall be mowed a minimum of three times and maintained at a maximum height of 3-inches. Do not cut more than 1/3 of a grass blade at during one mowing.
- B. Neatly trim edges and hand clip where necessary.
- C. Water to prevent grass and soil from drying out.
- D. Roll surface and top-dress with imported topsoil to remove irregularities.
- E. Weed Control: Apply a weed control herbicide. Notify the Architect prior to herbicide application. Apply herbicides in accordance with manufacturers' instructions. Remedy damage resulting from improper use of herbicides.
- F. Immediately sod areas that show deterioration or bare spots.
- G. Protect sodded areas with warning signs during maintenance period.

### **3.06 ACCEPTANCE OF SODDED AREAS**

- A. When sodding is substantially completed, including maintenance, the Architect will, upon request, make an inspection to determine acceptability.
- B. Sodded lawns will be acceptable, provided requirements, including maintenance, have been complied with, and healthy, uniform, close stand of specified grass is established, free of weeds, bare spots, open joints and surface irregularities.
- C. Where inspected work does not comply with requirements, replace defected work, and continue specified maintenance until re-inspected by the Architect and found to be acceptable.
- D. Once the work is accepted as complete, the Contractor will maintain the sodded areas until Final Acceptance of the project.

**END OF SECTION**

**SURVEY LEGEND**

⊙ AIR CONDITIONER	⊙ ELECTRIC MANHOLE	⊙ GAS MARKER	⊙ MISC. MARKER	⊙ SPRINKLER CONTROL VALVE	⊙ TREE - TREE	⊙ WATER MANHOLE
⊙ AREA DRAIN OR CATCH BASIN	⊙ ELECTRIC MARKER	⊙ GUARD POST	⊙ PIER	⊙ SANITARY SEWER LIFT STATION	⊙ TREE - TREE	⊙ SQUARE WATER METER
⊙ ALPHA BOX	⊙ ELECTRIC UTILITY TRANSFORMER	⊙ GREASE TRAP	⊙ PULLBOX	⊙ SIGNAL LIGHT	⊙ WATER SHUTOFF (SPRIG)	⊙ WATER WALK
⊙ AUTO SPRINKLER	⊙ FRENCH DRAIN	⊙ HIC SIGN	⊙ POWER METER	⊙ SPONGE TANK	⊙ WATER WALK	⊙ WATER WELL
⊙ AIR LEAK	⊙ FRESH HYDRANT	⊙ HIC PARKING	⊙ POWER POLE	⊙ STORM SEWER MANHOLE	⊙ WATER METER	⊙ HARD LIGHT
⊙ PROP. MCK	⊙ FRESH HYDRANT	⊙ HIC PARKING	⊙ POWER POLE	⊙ STORM SEWER MANHOLE	⊙ WATER METER	⊙ HARD LIGHT
⊙ BUSH	⊙ FRESH HYDRANT	⊙ HIC PARKING	⊙ POWER POLE	⊙ STORM SEWER MANHOLE	⊙ WATER METER	⊙ HARD LIGHT
⊙ CLEAN OUT	⊙ FRESH HYDRANT	⊙ HIC PARKING	⊙ POWER POLE	⊙ STORM SEWER MANHOLE	⊙ WATER METER	⊙ HARD LIGHT
⊙ DOWN SPOUT	⊙ FRESH HYDRANT	⊙ HIC PARKING	⊙ POWER POLE	⊙ STORM SEWER MANHOLE	⊙ WATER METER	⊙ HARD LIGHT
⊙ ELECTRIC METER	⊙ GAS METER	⊙ MONITORING WELL	⊙ SECTION CORNER	⊙ TELEPHONE MANHOLE	⊙ TELEPHONE MARKER	⊙ TELEPHONE METER
⊙ UNDERGROUND FIBER OPTIC	⊙ UNDERGROUND GAS	⊙ UNDERGROUND STORM SEWER	⊙ UNDERGROUND SANITARY SEWER	⊙ UNDERGROUND TELEPHONE	⊙ OVERHEAD ELECTRIC	⊙ OVERHEAD TELEPHONE
⊙ TOE OF BANK	⊙ TOP OF BANK	⊙ CHAINLINK FENCE	⊙ STOCKADE FENCE	⊙ BARBED WIRE FENCE		

**SITE CONSTRUCTION PLANS**  
**GRAND AVE ELEMENTARY PARKING ADDITION**  
 LOCATED IN THE NW QUARTER OF SECTION 4,  
 TOWNSHIP 6 NORTH, RANGE 7 WEST, 1.M.  
 CHICKASHA, GRADY COUNTY, OKLAHOMA

**THE CITY OF CHICKASHA**

**LWPB**  
 An LDG Company  
 3817 NW EXPRESSWAY  
 SUITE 400  
 OKLAHOMA CITY, OK 73112  
 (405) 722-7270

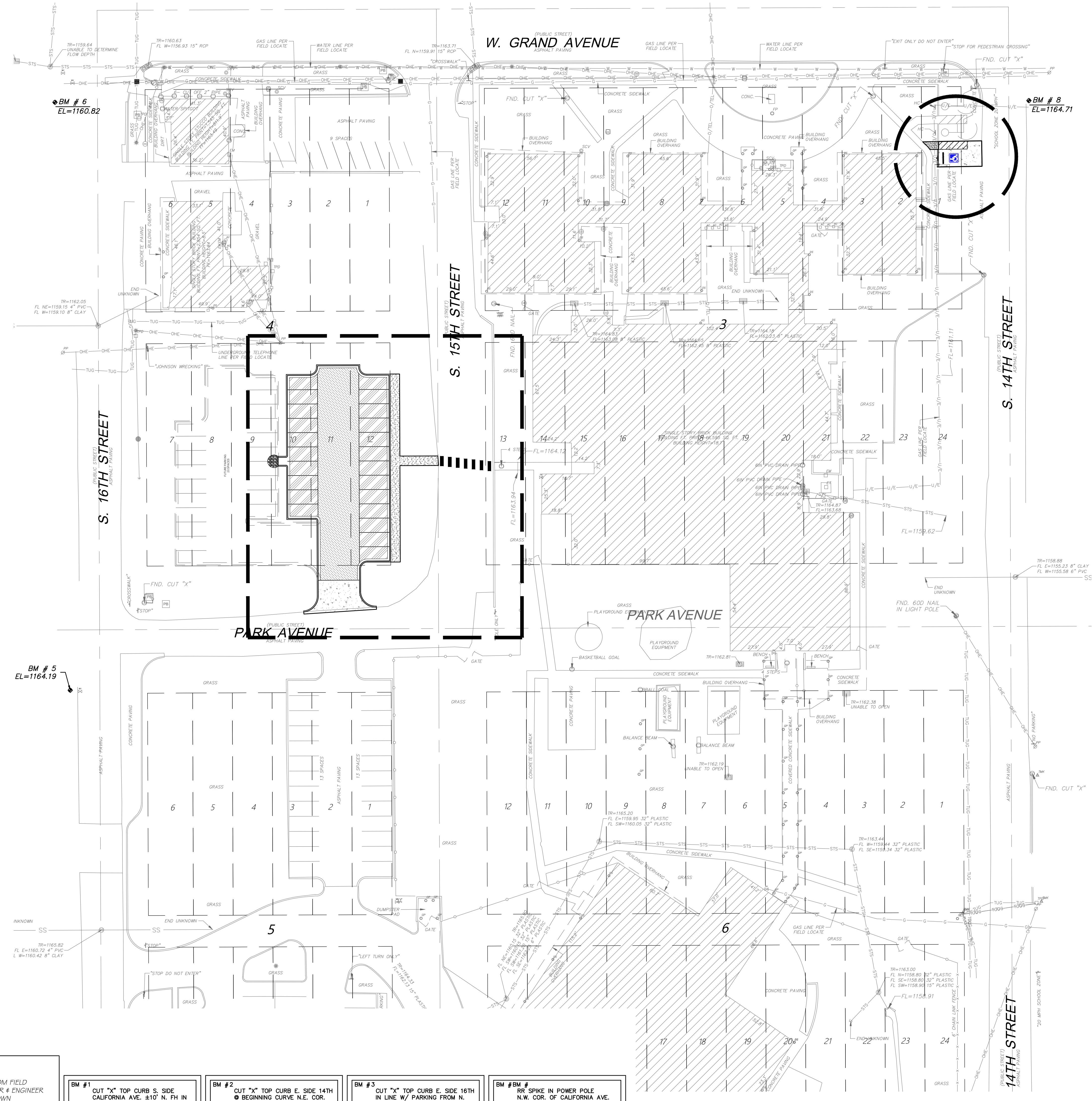
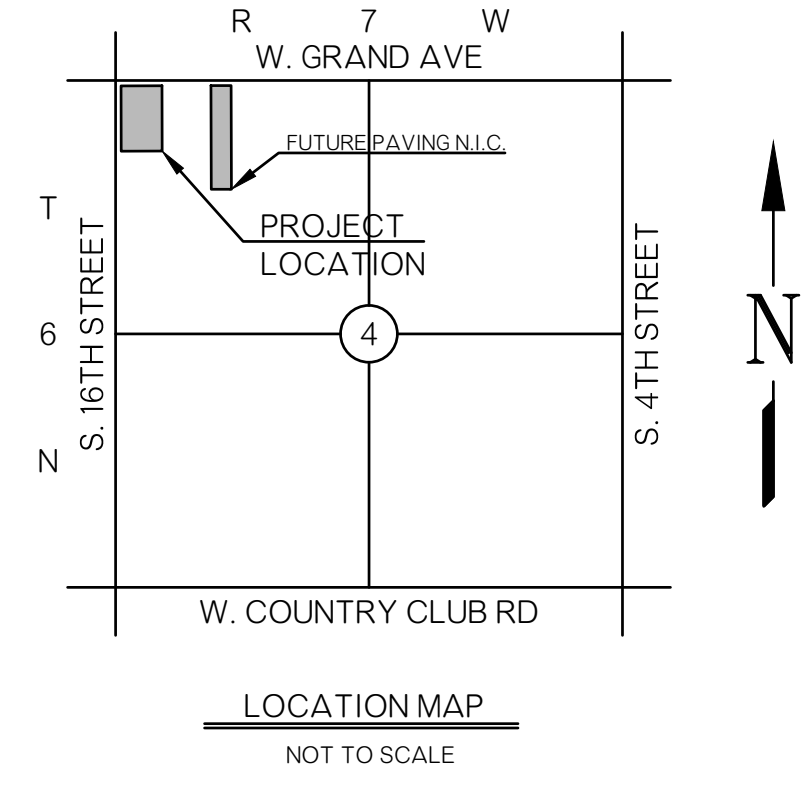

**PRIVATE PLAN SHEET INDEX**

SHEET NO.	TITLE SHEET	DESCRIPTION
C0.1	TITLE SHEET	OVERALL TOPOGRAPHIC SURVEY MAP
C1.0	TOPOGRAPHIC SURVEY - WEST	TOPOGRAPHIC SURVEY - WEST
C1.1	SITE DEMOLITION PLAN - WEST	SITE DEMOLITION PLAN - WEST
C2.0	SITE DEMOLITION PLAN - WEST	SITE DEMOLITION PLAN - WEST
C2.1	SITE DEMOLITION PLAN - EAST	SITE DEMOLITION PLAN - EAST
C3.0	SITE PLAN - WEST	SITE PLAN & GRADING PLAN - EAST
C3.1	SITE PLAN & GRADING PLAN - EAST	SITE PLAN & GRADING PLAN - EAST
C3.2	SITE CONSTRUCTION DETAILS	SITE CONSTRUCTION DETAILS
C4.0	GRADING PLAN - WEST	GRADING PLAN - WEST
C5.0	EROSION CONTROL PLAN - WEST	EROSION CONTROL PLAN - WEST
C5.1	EROSION CONTROL DETAILS	EROSION CONTROL DETAILS

**PRIMARY HORIZONTAL / VERTICAL CONTROL**

**HORIZONTAL DATUM:**  
 OKLAHOMA STATE PLANE SOUTH ZONE (EORS 2011)  
 MONUMENTS: POINT NO. 10003  
 DESCRIPTION: 1/2" I.P. W/ CAS949 CP CAP  
 N: 62060.736  
 E: 1983718.203  
 Z: 1145.723  
 POINT NO. 10004  
 DESCRIPTION: 1/2" I.P. W/ CAS949 CP CAP  
 N: 61690.350  
 E: 1983541.807  
 Z: 1158.481

**VERTICAL DATUM:**  
 OKLAHOMA STATE PLANE SOUTH ZONE (EORS 2011)  
 NAVD 88, GEOID 18  
 MONUMENTS: POINT NO. 10003  
 DESCRIPTION: 1/2" I.P. W/ CAS949 CP CAP  
 N: 62060.736  
 E: 1983718.203  
 Z: 1145.723



**UTILITY STATEMENT:**  
 THE UNDERGROUND UTILITIES SHOWN HAVE BEEN LOCATED FROM FIELD SURVEY INFORMATION AND EXISTING DRAWINGS. THE SURVEYOR & ENGINEER MAKES NO GUARANTEE THAT THE UNDERGROUND UTILITIES SHOWN COMPRISE ALL SUCH UTILITIES IN THE AREA, EITHER IN SERVICE OR ABANDONED. THE SURVEYOR & ENGINEER FURTHER DOES NOT WARRANT THAT THE UNDERGROUND UTILITIES SHOWN ARE IN THE EXACT LOCATION INDICATED ALTHOUGH HE DOES CERTIFY THAT THEY ARE LOCATED AS ACCURATELY AS POSSIBLE FROM INFORMATION AVAILABLE. THE SURVEYOR & ENGINEER HAS NOT PHYSICALLY LOCATED THE UNDERGROUND UTILITIES. CONTRACTOR IS RESPONSIBLE IN VERIFYING LOCATION OF UTILITIES.

<b>BM #1</b> CUT "X" TOP CURB S. SIDE CALIFORNIA AVE. 150' N. FRI IN S.W. COR. INTERSECTION 14TH ST. ELEV=1158.02	<b>BM #2</b> CUT "X" TOP CURB E. SIDE 14TH ARIZONA AVE. INTERSECTION ELEV=1160.48	<b>BM #3</b> CUT "X" TOP CURB E. SIDE 16TH IN LINE W/ PARKING FROM N. END OF S.W. PARKING ELEV=1169.35	<b>BM #4</b> RR SPIKE IN POWER POLE N.W. COR. OF CALIFORNIA AVE. AND 16TH ST. INTERSECTION ELEV=1168.69
<b>BM #5</b> CUT "X" ON MIDDLE CURVE N. SIDE CONC. DRIVEWAY AT 2210 16TH ST. ELEV=1164.78	<b>BM #6</b> CUT "X" TOP OF CURB ON WEST SIDE OF 16TH ST. AT RETURN OF CURB FROM GRAND ELEV=1160.82	<b>BM #7</b> CUT "X" ON N. SIDE W. GRAND AT RETURN OF CURB FROM 15TH STREET ELEV=1164.29	<b>BM #8</b> CUT "X" TOP CURB E. SIDE 14TH ST. AT CURB RETURN FROM GRAND. END OF CURB ELEV=1164.71

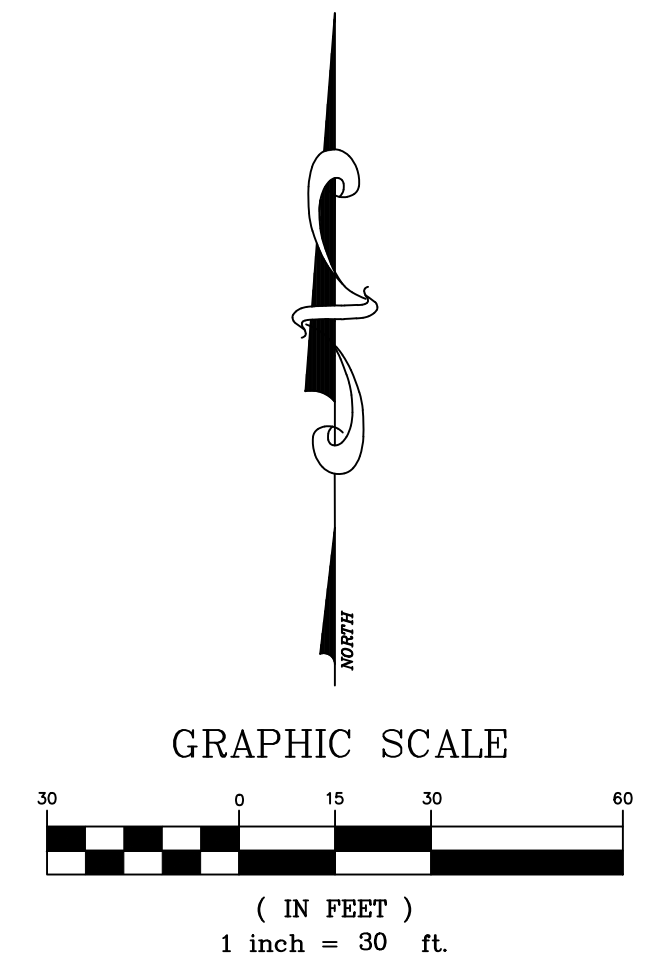

**CHICKASHA PUBLIC SCHOOLS**  
**GRAND AVENUE ELEMENTARY**  
**PARKING AND PAVING IMPROVEMENTS**  
 1415 W. GRAND AVE, Chickasha, OK 73018

JOB NO: 116838 TASK 1  
 DATE: 02/13/2014

REVISIONS

NO.	DESCRIPTION

DRAWING TITLE  
 TITLE SHEET

**SRB ENGINEERING SURVEYING PLANNING**  
 CERTIFICATE OF AUTHORIZATION  
 NO. 9949 EXPIRES JUNE 30, 2025

**C0.1**

LOCAL FILE: BM 380\K\Kingsfisher 2022 Gilmore and Football Concession Renovations\2022 Gilmore Elementary.rvt  
 CENTRAL FILE: 2/9/2023 2:53:52 PM  
 LWPB JOB: 22-1511-E008  
 TEMPLATE: LWPB 2019.0002  
 Z:\116838\Private Site Development\Task 1 - Grand Elementary\116838-PLAN - GRAND.ssm.mazzano 2.13.24. 04:11pm











**SURVEY LEGEND**

⊕ AIR CONDITIONER	⊕ ELECTRIC MANHOLE	⊕ GAS MARKER	⊕ MISC. MARKER	⊕ SPRINKLER CONTROL VALVE	⊕ TREE - TREE	⊕ WATER MANHOLE
⊕ AREA DRAIN OR CATCH BASIN	⊕ ELECTRIC MARKER	⊕ GREASE TRAP	⊕ PIER	⊕ SANITARY SEWER LIFT STATION	⊕ TREE - TREE	⊕ SQUARE WATER METER
⊕ ALPHA BOX	⊕ ELECTRIC UTILITY TRANSFORMER	⊕ GAS VALVE	⊕ PARKING METER	⊕ TR=XX.XX' TRAFFIC CONTROL BOX	⊕ TRAFFIC CONTROL BOX	⊕ WATER SHUTOFF (SPRIG)
⊕ AUTO SPRINKLER	⊕ FREIGHT CRAN	⊕ HC SON	⊕ POWER POLE	⊕ SPRING TANK	⊕ TR=XX.XX' TRAFFIC CONTROL BOX	⊕ WATER WALK
⊕ AIR VENT	⊕ FIRE HYDRANT	⊕ HC PARKING	⊕ TR=XX.XX' TRAFFIC CONTROL BOX	⊕ TR=XX.XX' TRAFFIC CONTROL BOX	⊕ TR=XX.XX' TRAFFIC CONTROL BOX	⊕ WATER WELL
⊕ PREP. MCK	⊕ FIRE VALVE	⊕ INLET	⊕ QUARTER CORNER NORTH-SOUTH	⊕ QUARTER CORNER EAST-WEST	⊕ TR=XX.XX' TRAFFIC CONTROL BOX	⊕ HARD LIGHT
⊕ BUSH	⊕ CLEAN OUT	⊕ FIRE VALVE	⊕ QUARTER CORNER NORTH-SOUTH	⊕ QUARTER CORNER EAST-WEST	⊕ TR=XX.XX' TRAFFIC CONTROL BOX	⊕ BM #1 EL=XX.XX'
⊕ DOWN SPOUT	⊕ GAS METER	⊕ MAL BOX	⊕ REFERENCE POINT	⊕ TELEPHONE MARKER	⊕ TELEPHONE PEDESTAL	⊕ FOUND WATER METER
⊕ ELECTRIC METER	⊕ GAS METER	⊕ MONITORING WELL	⊕ SECTION CORNER	⊕ TELEPHONE PEDESTAL	⊕ TELEPHONE PEDESTAL	⊕ FOUND WATER METER

**SITE LEGEND**

	6" CONCRETE PAVEMENT
	CONCRETE SIDEWALK
	6" INTEGRAL CURB
	PROPOSED RETAINING WALL

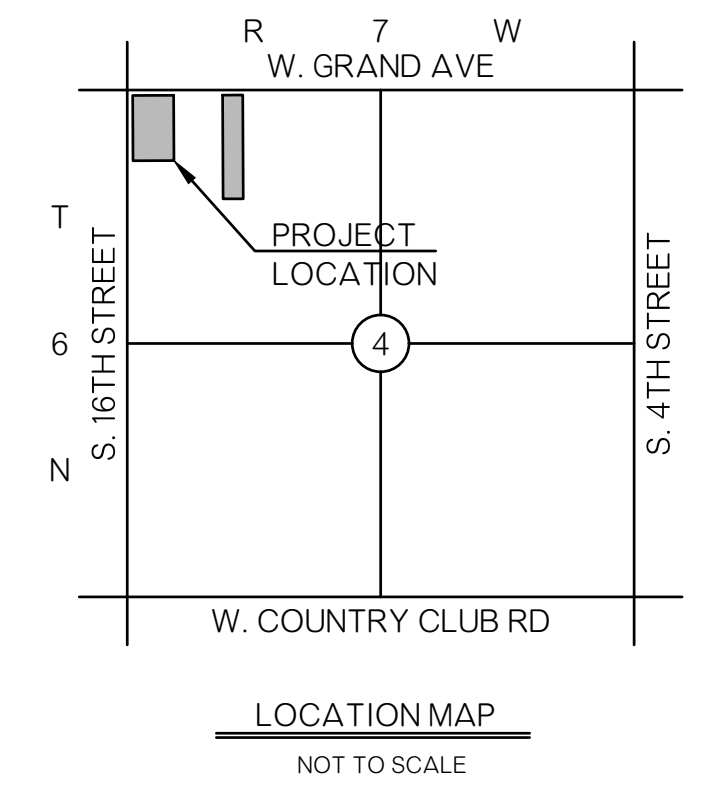

**LWPB**  
An LDC Company

3817 NW EXPRESSWAY  
OKLAHOMA CITY, OK 73112  
(405) 722-7270

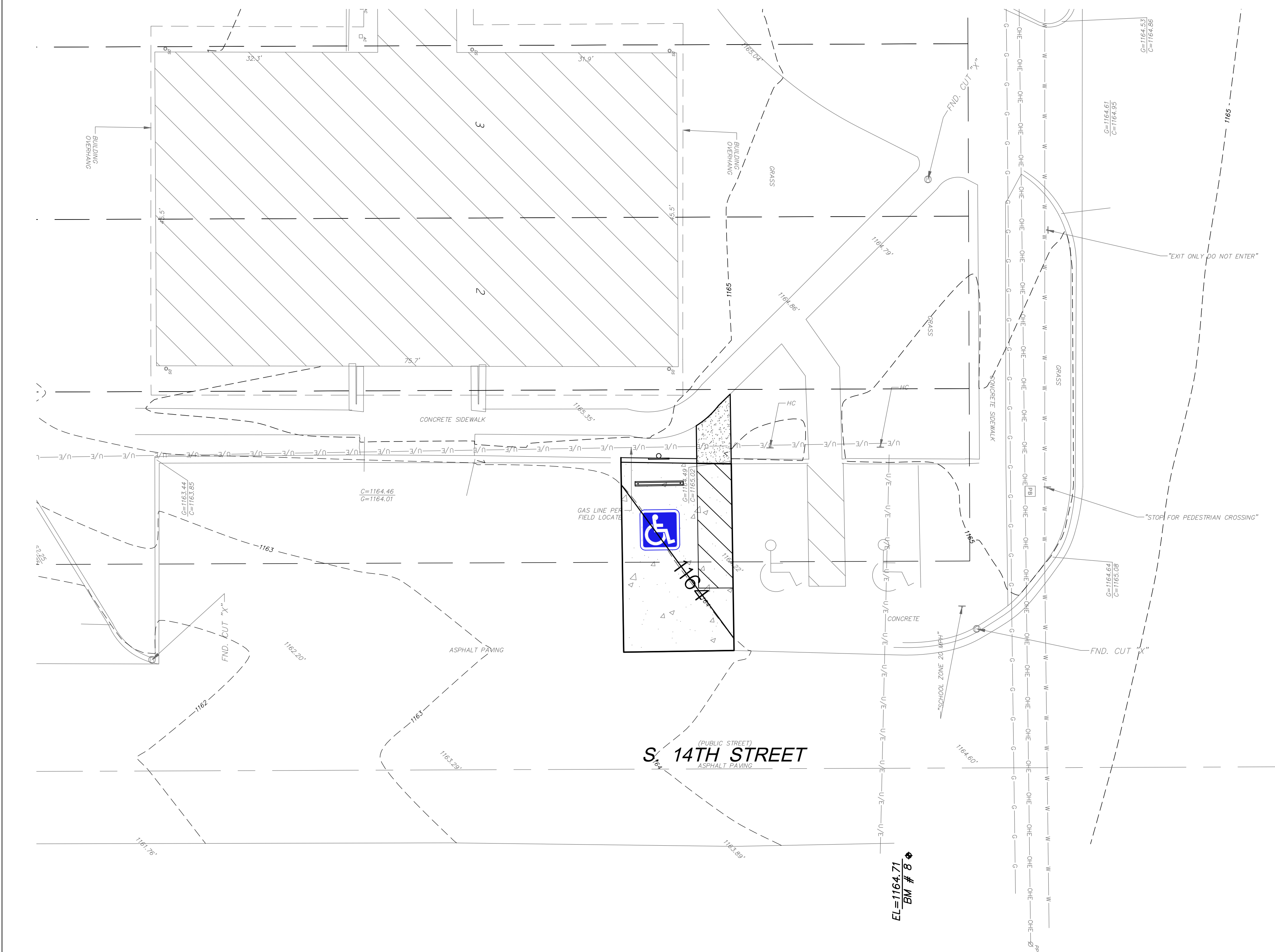
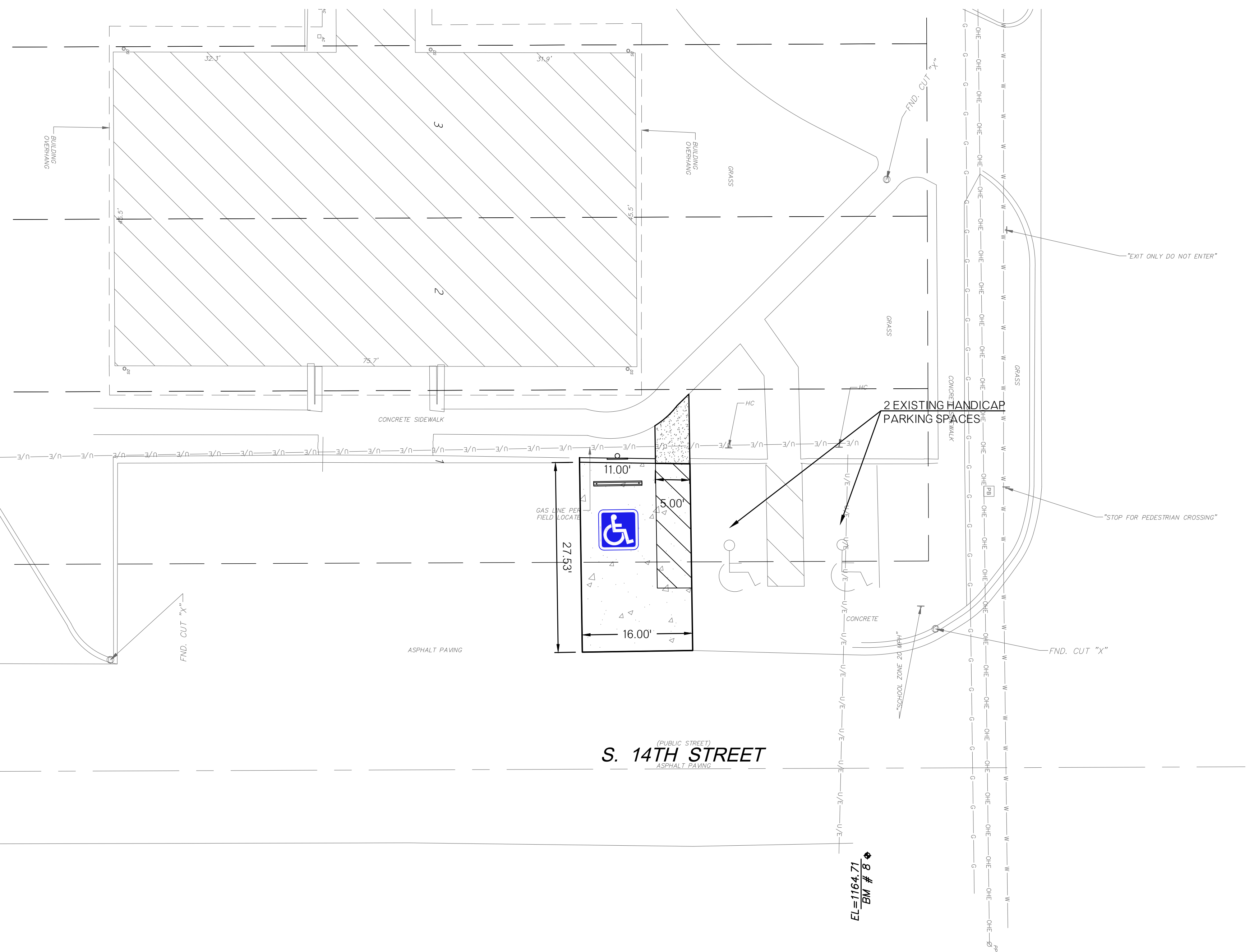

**PRIMARY HORIZONTAL / VERTICAL CONTROL**

**HORIZONTAL DATUM:**  
OKLAHOMA STATE PLANE SOUTH ZONE (EORS 2011)  
MONUMENTS: POINT NO. 10003  
DESCRIPTION: 1/2" I.P. W/ CA3949 CP CAP  
N: 62066.736  
E: 1983218.203  
Z: 1145.723  
POINT NO. 10004  
DESCRIPTION: 1/2" I.P. W/ CA3949 CP CAP  
N: 61690.350  
E: 1983541.807  
Z: 1158.481

**VERTICAL DATUM:**  
OKLAHOMA STATE PLANE SOUTH ZONE (EORS 2011)  
NAVD 88, GEOID 18  
MONUMENTS: POINT NO. 10003  
DESCRIPTION: 1/2" I.P. W/ CA3949 CP CAP  
N: 62066.736  
E: 1983218.203  
Z: 1145.723

**UTILITY STATEMENT:**  
THE UNDERGROUND UTILITIES SHOWN HAVE BEEN LOCATED FROM FIELD SURVEY INFORMATION AND EXISTING DRAWINGS. THE SURVEYOR & ENGINEER MAKES NO GUARANTEE THAT THE UNDERGROUND UTILITIES SHOWN COMPRISE ALL SUCH UTILITIES IN THE AREA, EITHER IN SERVICE OR ABANDONED. THE SURVEYOR & ENGINEER FURTHER DOES NOT WARRANT THAT THE UNDERGROUND UTILITIES SHOWN ARE IN THE EXACT LOCATION INDICATED ALTHOUGH HE DOES CERTIFY THAT THEY ARE LOCATED AS ACCURATELY AS POSSIBLY FROM INFORMATION AVAILABLE. THE SURVEYOR & ENGINEER HAS NOT PHYSICALLY LOCATED THE UNDERGROUND UTILITIES. CONTRACTOR IS RESPONSIBLE IN VERIFYING LOCATION OF UTILITIES.



<b>BM #1</b> CUT "X" TOP CURB S. SIDE CALIFORNIA AVE. 510' N. 7TH IN S.W. COR. INTERSECTION 14TH ST. ELEV=1158.02	<b>BM #2</b> CUT "X" TOP CURB E. SIDE 14TH ST. INTERSECTION ARIZONA AVE. INTERSECTION ELEV=1160.46	<b>BM #3</b> CUT "X" TOP CURB E. SIDE 16TH ST. IN LINE W/ PARKING FROM N. END OF S.W. PARKING ELEV=1169.35	<b>BM #4</b> RR SPIKE IN POWER POLE N.W. COR. OF CALIFORNIA AVE. AND 16TH ST. INTERSECTION ELEV=1168.69
<b>BM #5</b> CUT "X" ON MIDDLE CURVE N. SIDE CONC. DRIVEWAY AT 2210 16TH ST. ELEV=1164.79	<b>BM #6</b> CUT "X" TOP OF CURB ON WEST SIDE OF 16TH ST. AT RETURN OF CURB FROM GRAND ELEV=1160.82	<b>BM #7</b> CUT "X" ON N. SIDE W. GRAND AT RETURN OF CURB FROM 15TH STREET ELEV=1164.29	<b>BM #8</b> CUT "X" TOP CURB E. SIDE 14TH ST. AT CURB RETURN FROM GRAND. END OF CURB ELEV=1164.71

**NOTE: PROVIDE SOLID SLAB SOD IN ALL DISTURBED AREAS UNLESS SHOWN OTHERWISE ON THE LANDSCAPE PLANS.**

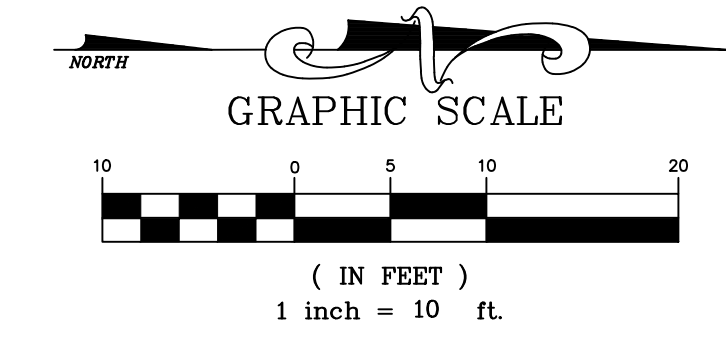

**SRB** ENGINEERING SURVEYING PLANNING  
CERTIFICATE OF AUTHORIZATION NO. 9949 EXPIRES JUNE 30, 2025

**CHICKASHA PUBLIC SCHOOLS  
GRAND AVENUE ELEMENTARY  
PARKING AND PAVING IMPROVEMENTS**  
1415 W. GRAND AVE, Chickasha, OK 73018

JOB NO: 116838 TASK 1  
DATE: 02/13/2014

REVISIONS

DRAWING TITLE  
SITE PLAN & GRADING PLAN - EAST PARKING

**C3.1**

LOCAL FILE: B:\380\Kingfisher 2022 Gilmore and Football Concession Renovations\2022 Gilmore Elementary.rvt  
CENTRAL FILE: 2/9/2023 2:53:52 PM  
LWPB JOB: 2214511.E008  
TEMPLATE: LWPB 2019.0002  
Z:\116838\Private Site Development\Task 1 - Grand Elementary\116838.PLAN - GRAND.ssm.mazzano.2.13.24.04.11.dwg



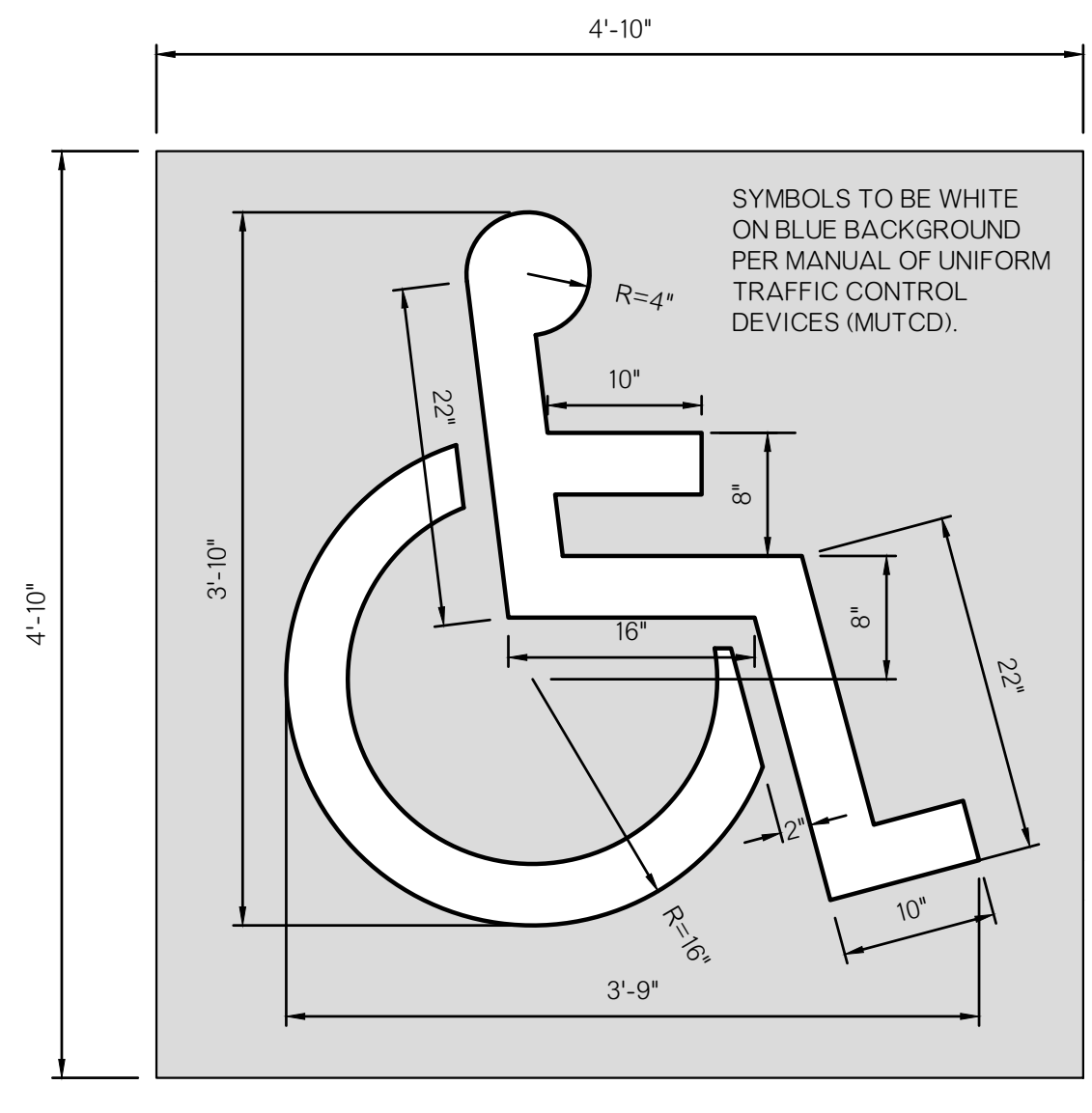

**HANDICAP PAVEMENT MARKING DETAIL**  
NO SCALE

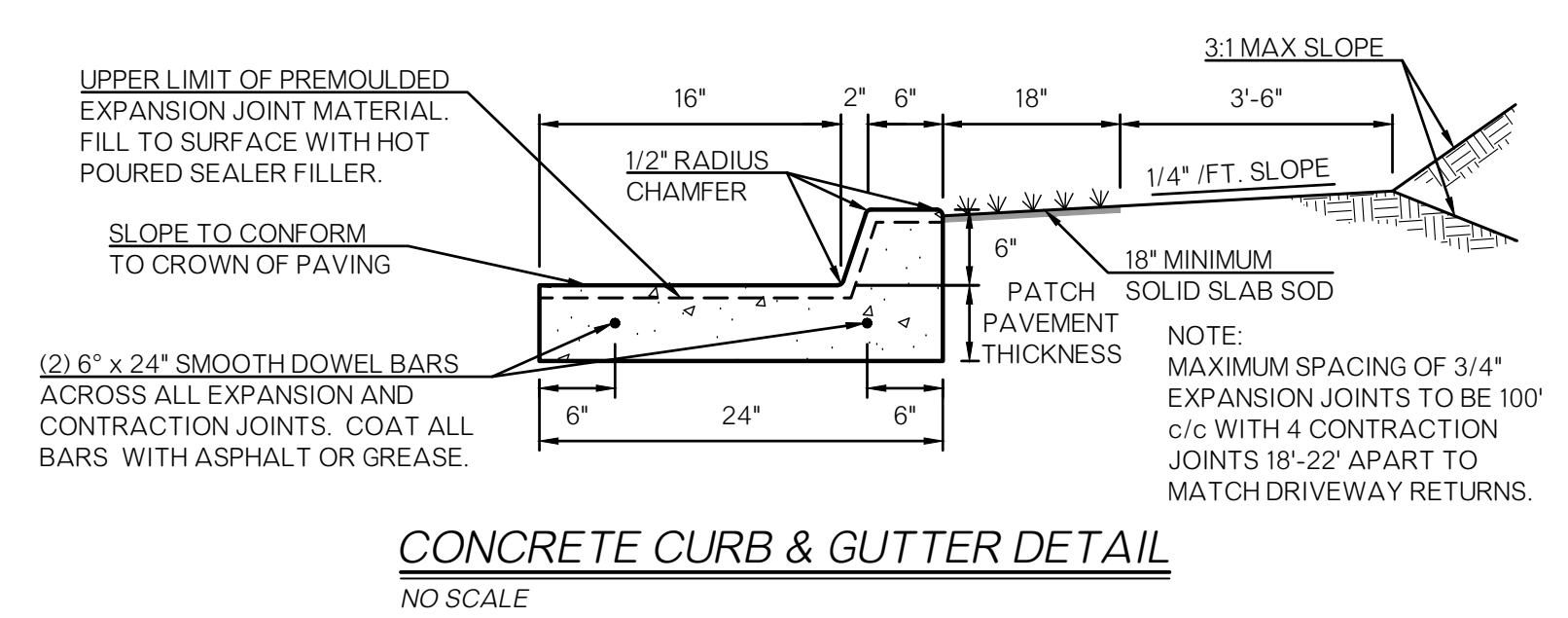

**CONCRETE CURB & GUTTER DETAIL**  
NO SCALE

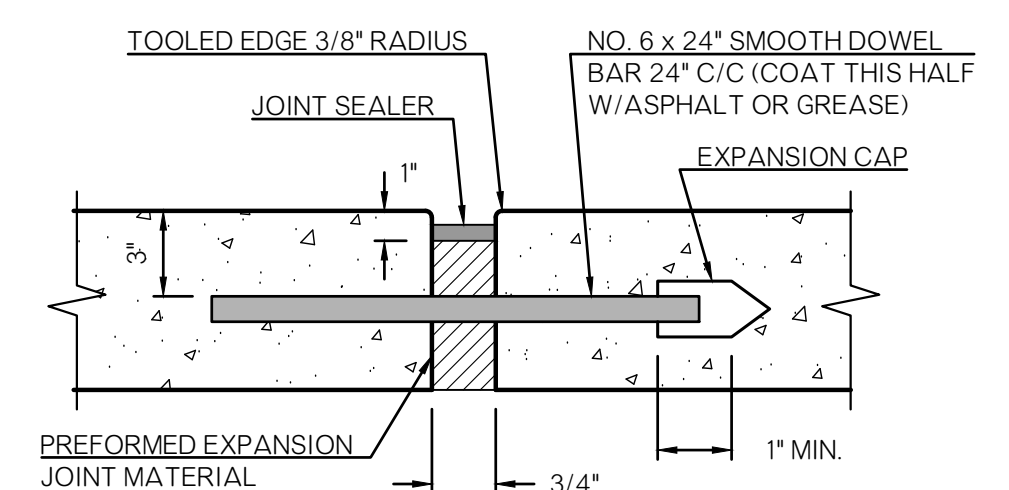

**EXPANSION JOINT**  
NO SCALE

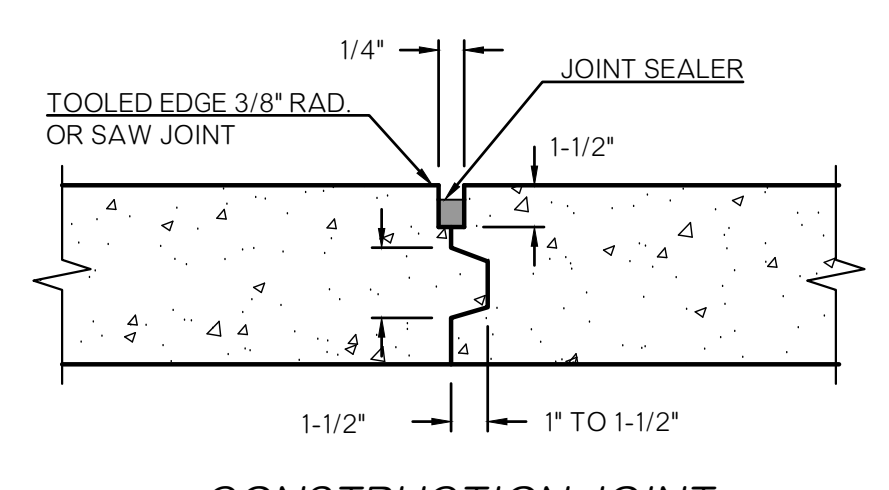

**CONSTRUCTION JOINT**  
NO SCALE

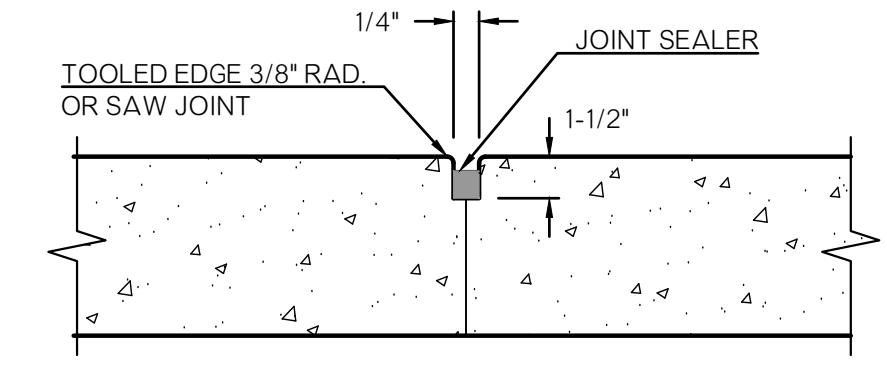

**CONTRACTION JOINT**  
NO SCALE

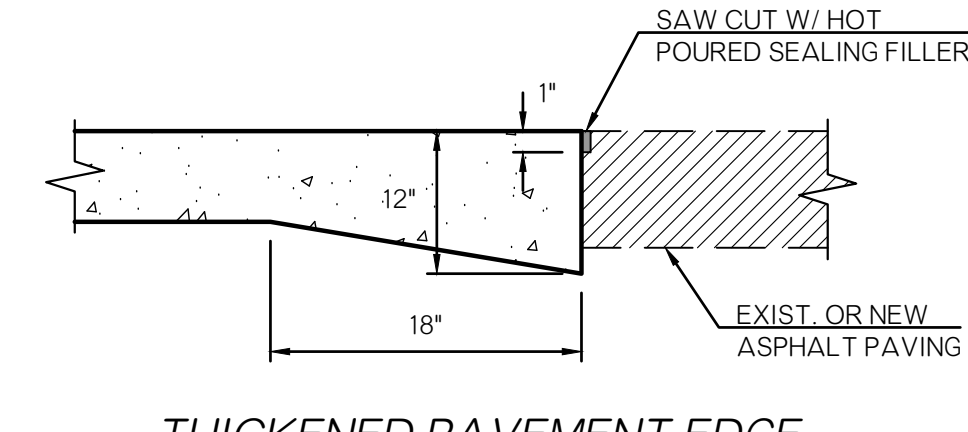

**THICKENED PAVEMENT EDGE**  
(TYPICAL AT CONCRETE & ASPHALT JOINT)

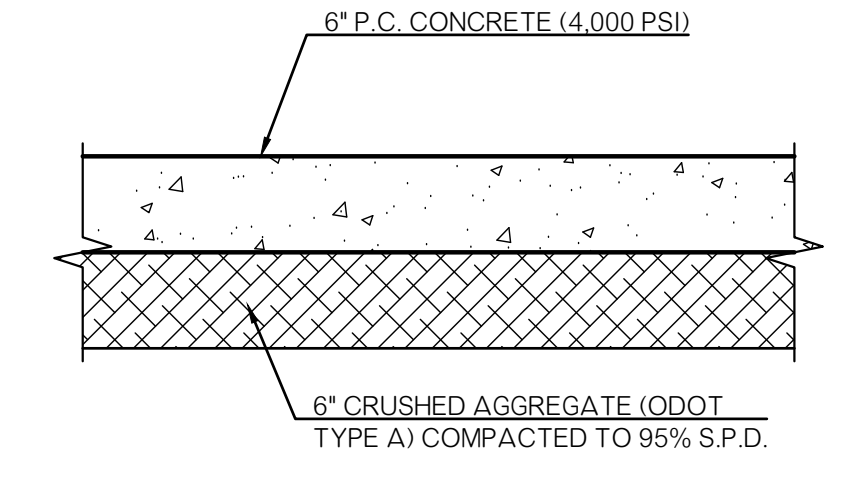

**P.C. CONCRETE PAVING SECTION**

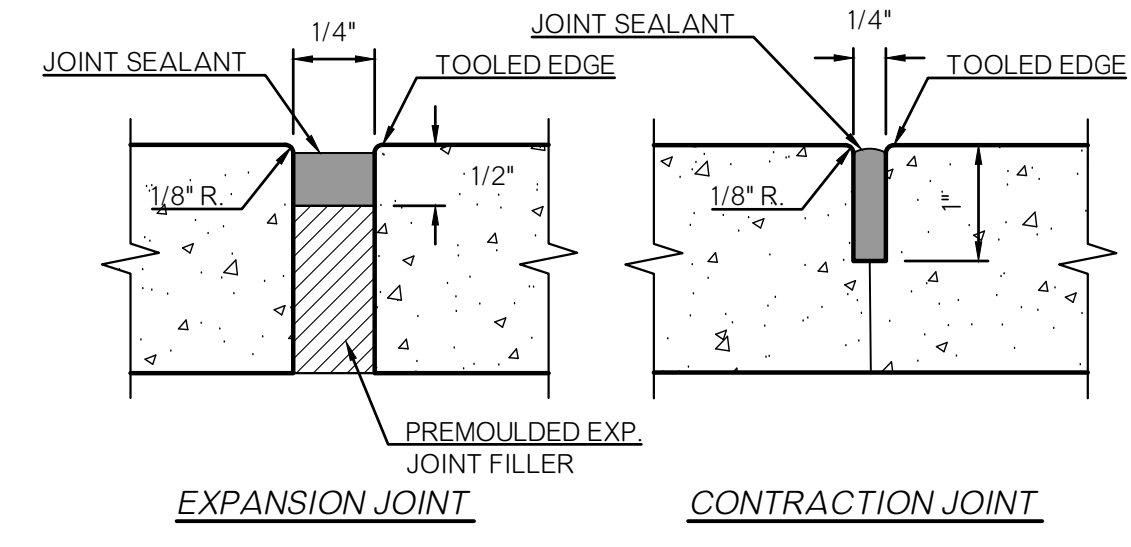

**SIDEWALK JOINT DETAILS**  
NO SCALE

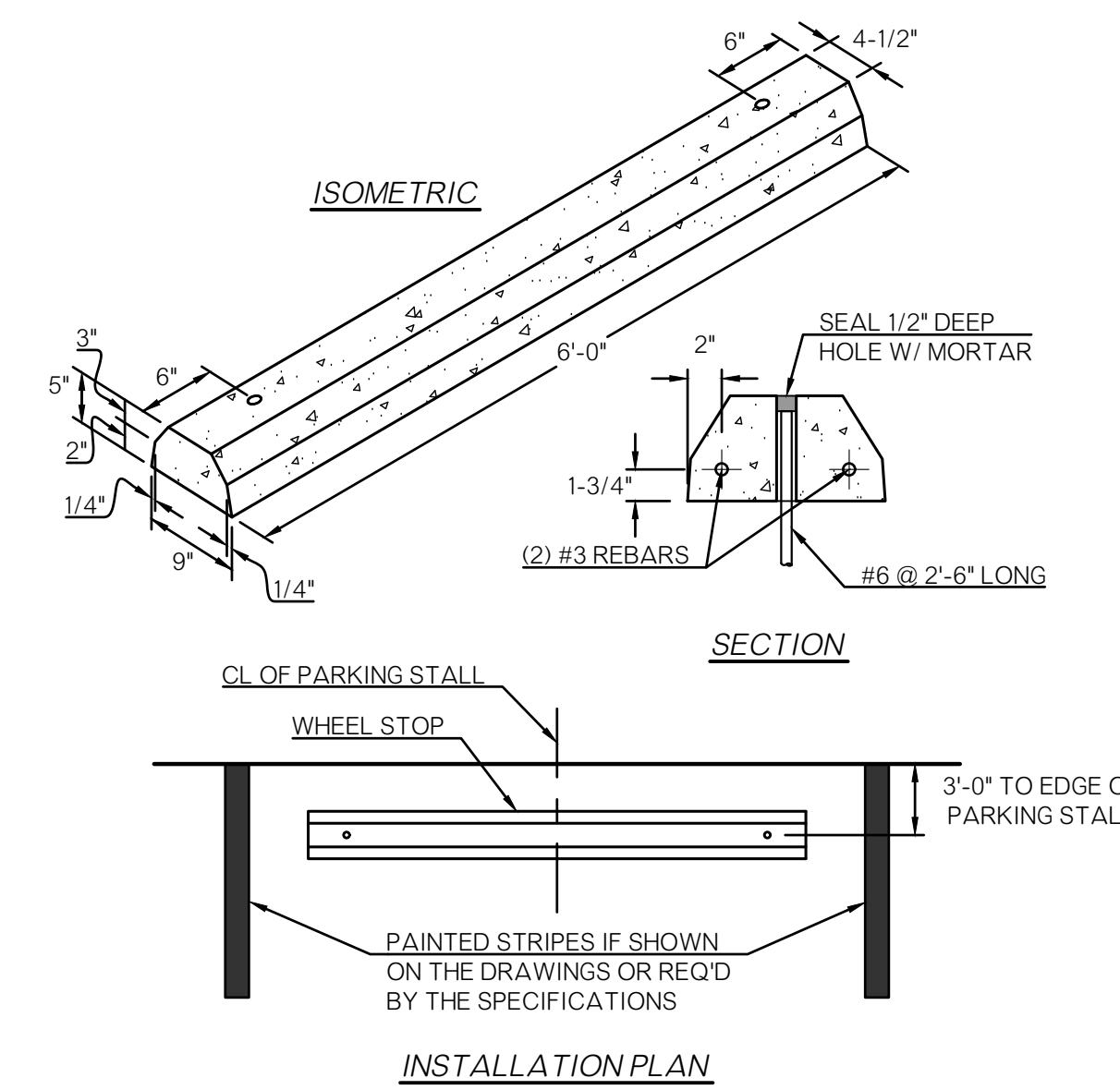

**PRECAST CONCRETE WHEEL STOP DETAILS**  
NO SCALE

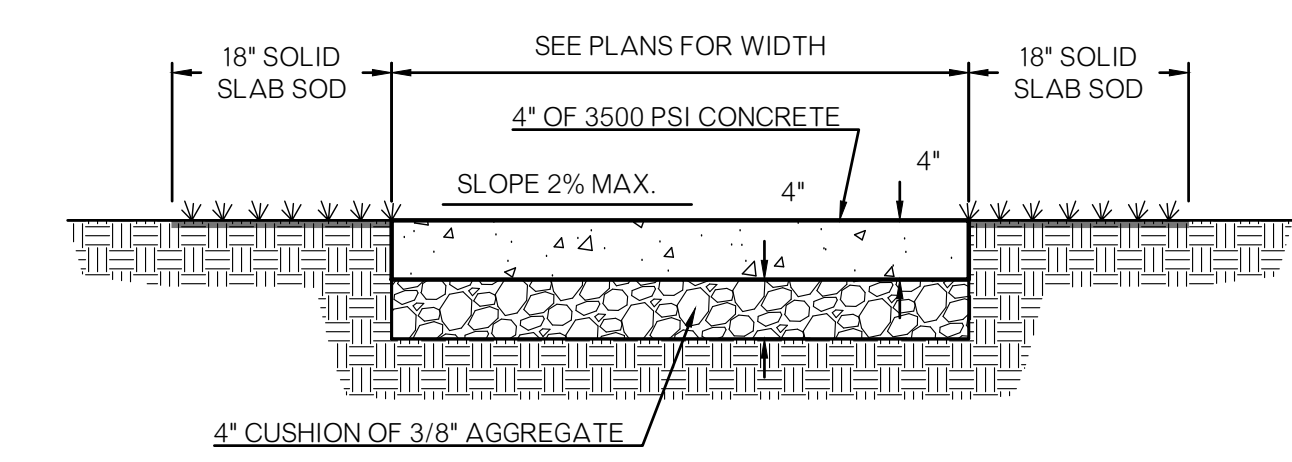

- NOTES:
- SPACE TRANSVERSE CONTRACTION JOINTS UNIFORMLY AT INTERVALS EQUAL TO THE WALK WIDTH OS AS SHOWN ON ARCHITECTURAL DRAWINGS.
  - PLACE PRE-MOLDED EXPANSION JOINT MATERIAL AROUND ALL STRUCTURES IN NEW WALK ALONGSIDE ALL ADJACENT BUILDING AND ADJUTTING STRUCTURES TO THE NEW CONCRETE SIDEWALK.
  - 1/2" EXPANSION JOINTS SHALL BE SPACED NOT MORE THAN 60'-0" O.C.
  - SEAL EXPANSION & CONTRACTION JOINTS WITH AN APPROVED TYPE SEALANT, REFER TO SPECIFICATIONS.

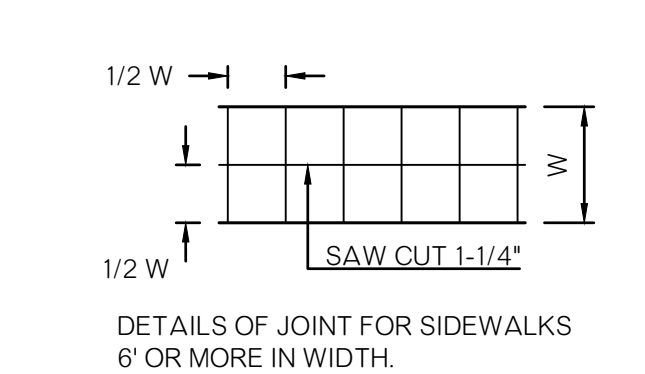

**TYPICAL SIDEWALK SECTION**  
NO SCALE

- NOTES:
- 1/2" X 4" PREMOULDED EXPANSION MATERIAL AROUND POWER POLES OR OTHER STRUCTURES IN WALK, WITH AT LEAST 36" OF CLEAR TRAVEL SPACE.
  - EXPANSION JOINTS MAXIMUM DISTANCE = 100'. USED 1/2" X 4" PREMOULDED EXPANSION MATERIAL.
  - TRANSVERSE CONTRACTION JOINTS MAXIMUM DISTANCE = 5'. SAW CUT OR TOOL 1 1/4" DEEP.
  - SAW CUT JOINTS WITHIN 24 HOURS.
  - USE 1/2" X 4" PREMOULDED EXPANSION JOINT AT CURB.

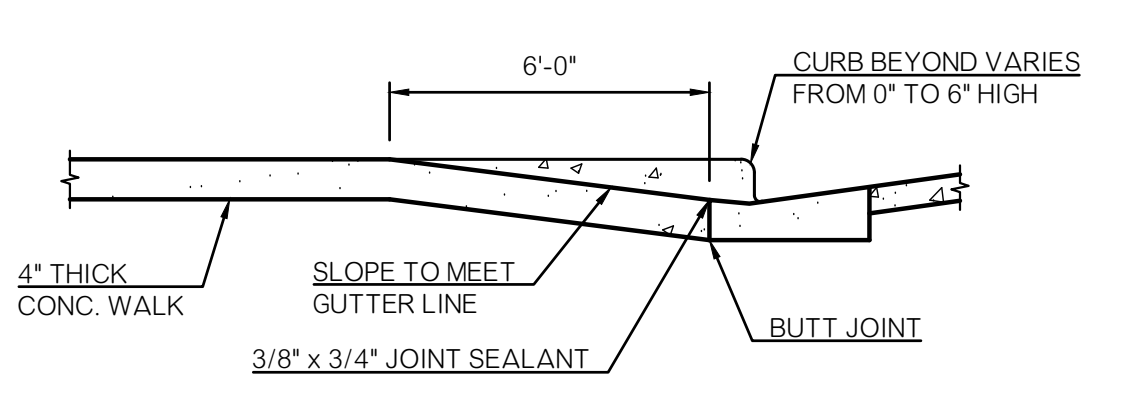

**HANDICAP CURB-RAMP DETAIL**  
NO SCALE

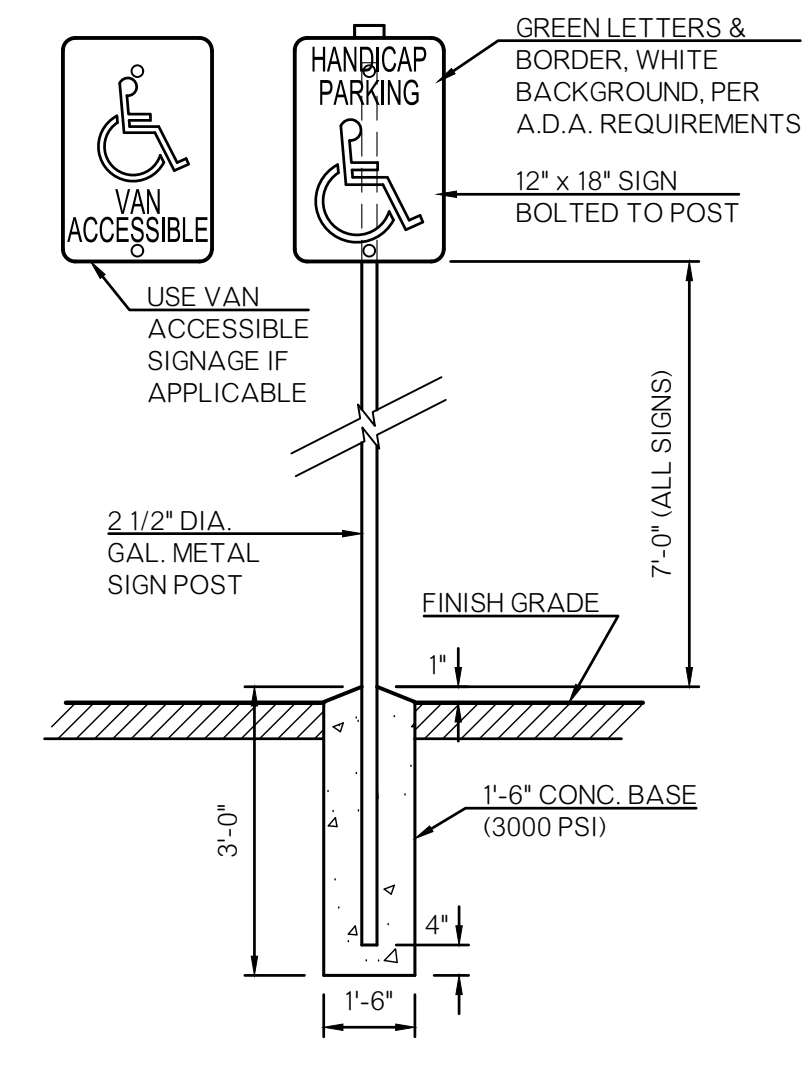

**HANDICAP SIGN DETAIL**  
NO SCALE

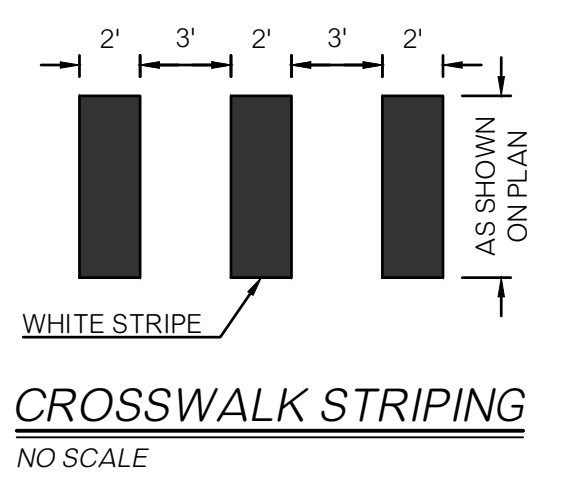
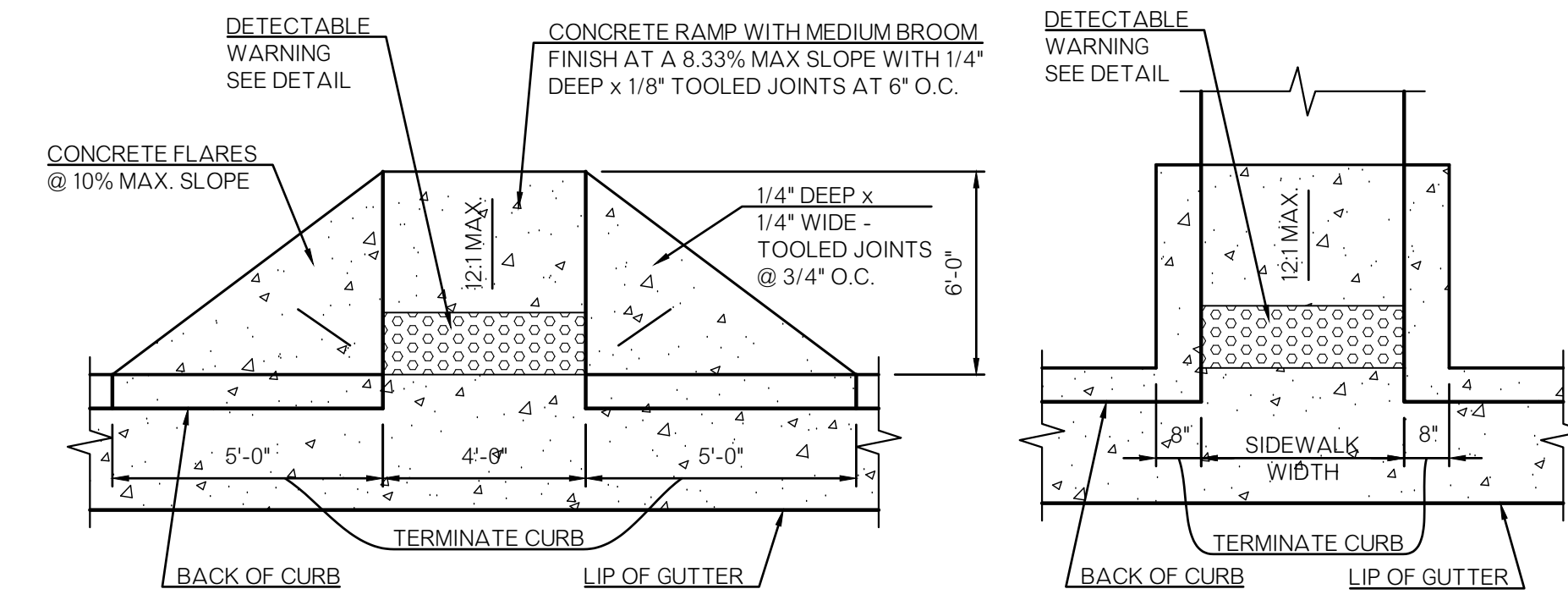

**CROSSWALK STRIPING**  
NO SCALE

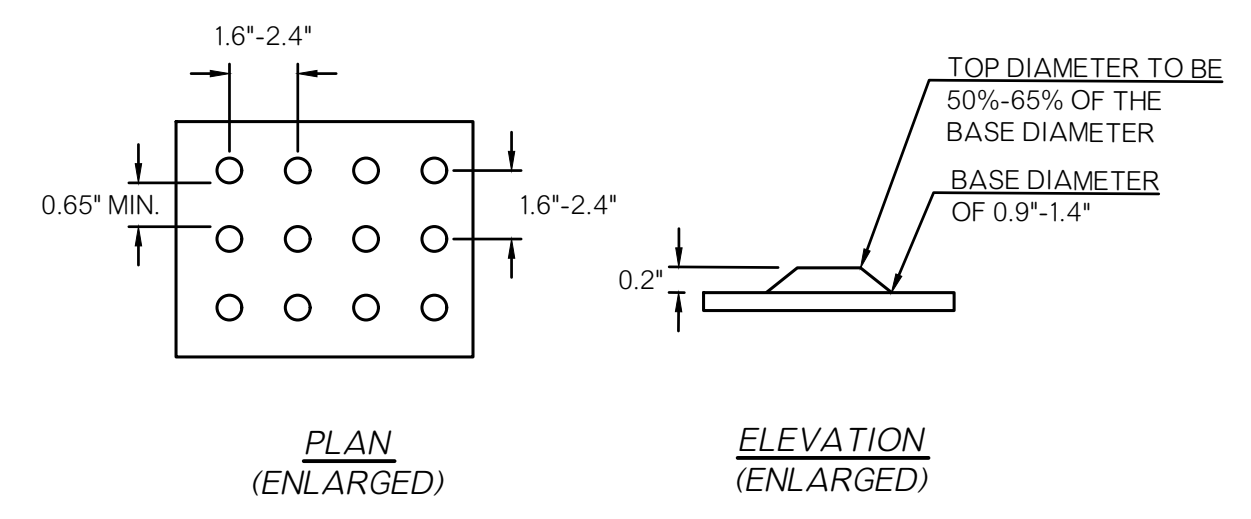

- DETECTABLE WARNING SURFACE SPECIFICATIONS:**
- MUST PROVIDE A VISUAL CONTRAST.
  - RAISED TACTILE SURFACES USED FOR WAY FINDING.
  - DETECTABLE WARNING SURFACE SHALL BE INSTALLED IN A MANNER SUCH THAT THE DOMES ARE PARALLEL TO THE DIRECTION OF PEDESTRIAN TRAVEL.
  - INSTALL THE DETECTABLE WARNING SURFACE BEGINNING AT BACK OF CURB.

**DETECTABLE WARNING SURFACE PATTERN DETAIL**  
NO SCALE

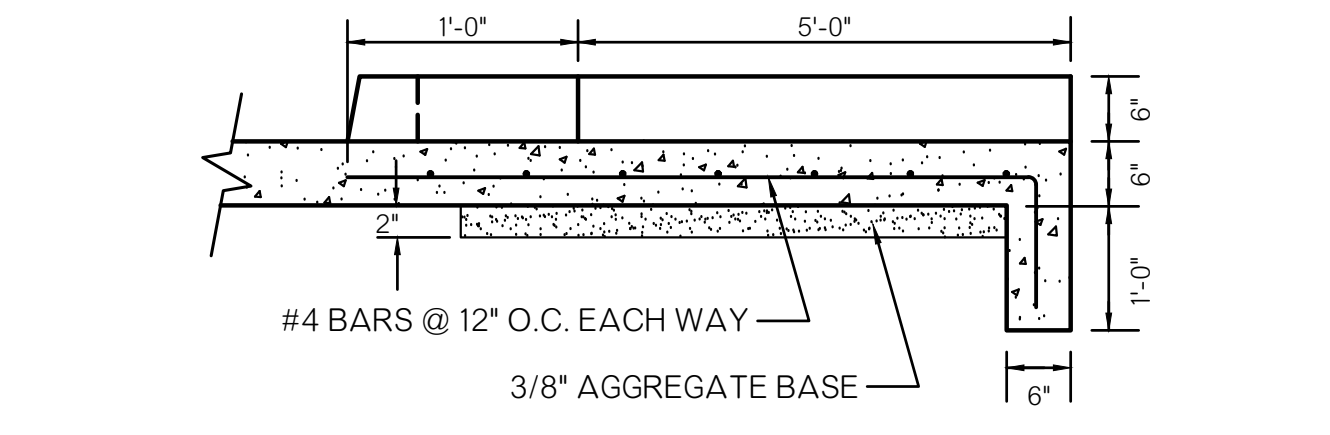

**SECTION A-A**

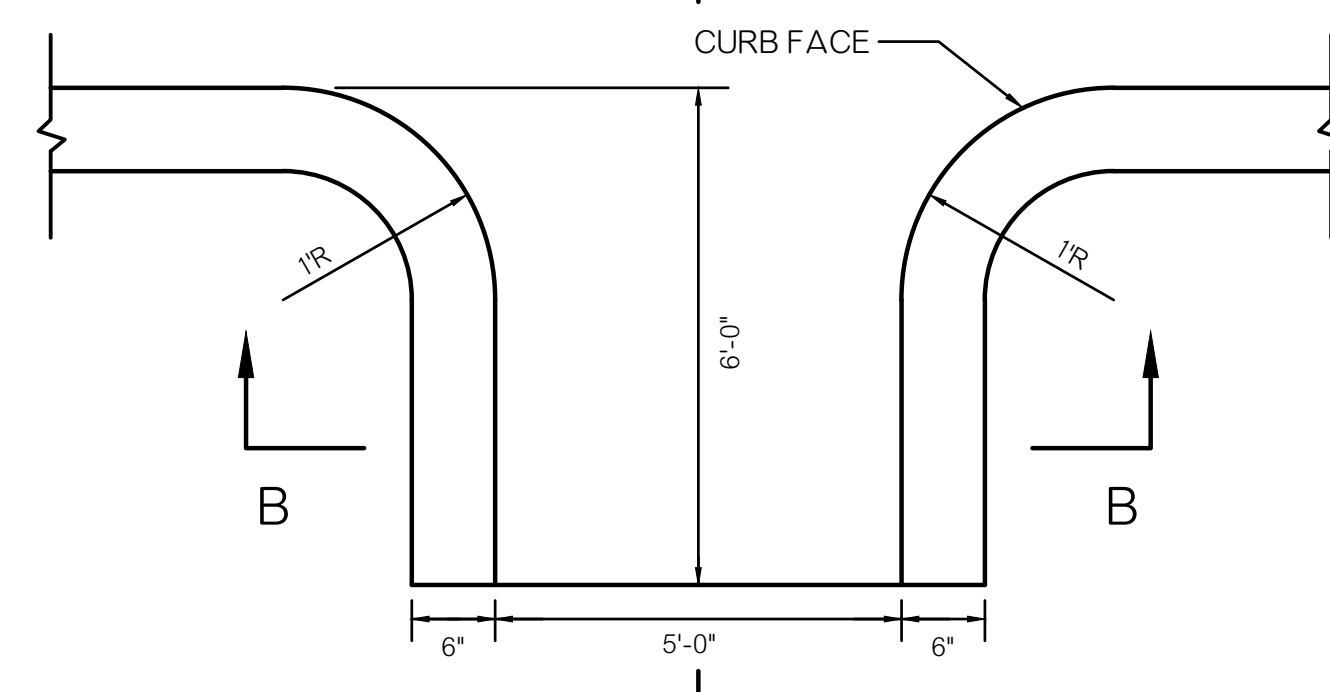

**SECTION B-B**

NOTE: EXPANSION JOINTS SHALL BE PLACED @ 50' INTERVALS & CONTROL JOINTS SAWED @ 10' INTERVALS. POUR HOT SEALER IN JOINTS.

**CONCRETE CURB GAP DETAILS**  
NO SCALE

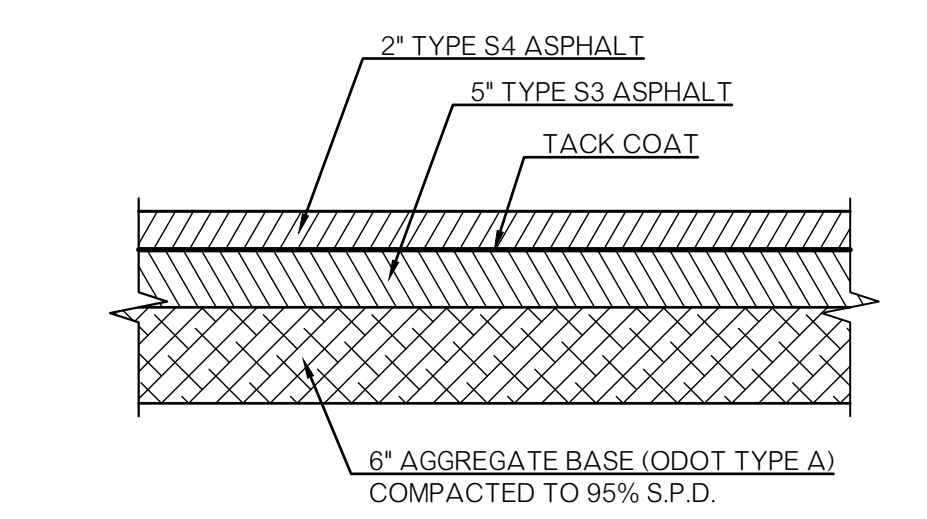

**HEAVY DUTY ASPHALT PAVING SECTION**  
NO SCALE

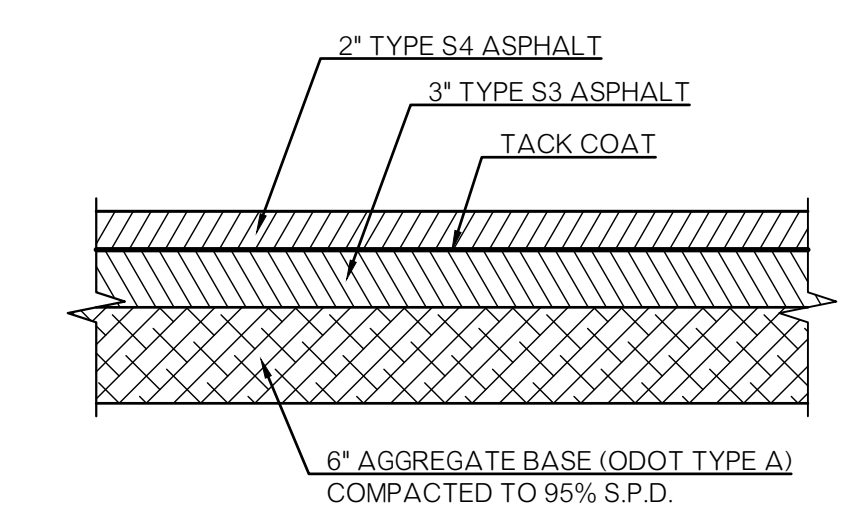

**LIGHT DUTY ASPHALT PAVING SECTION**  
NO SCALE



**CHICKASHA PUBLIC SCHOOLS  
GRAND AVENUE ELEMENTARY  
PARKING AND PAVING IMPROVEMENTS**  
1415 W. GRAND AVE, Chickasha, OK 73018

JOB NO: 116838 TASK 1  
DATE: 02/13/2014

REVISIONS

DRAWING TITLE  
SITE CONSTRUCTION DETAILS

**C3.2**



**ENGINEERING SURVEYING PLANNING**  
CERTIFICATE OF AUTHORIZATION NO. 9949 EXPIRES JUNE 30, 2025

LOCAL FILE: B:\380\K\Kingsfisher 2022 Gilmore and Football Concession Renovations\2022 Gilmore Elementary.rvt  
CENTRAL FILE: 2/9/2023 2:53:52 PM  
LWPB JOB: 22-1511-E908  
TEMPLATE: LWPB 2019.0002  
Z:\116838\Private\_Site\_Development\Task 1 - Grand Elementary\116838-PLAN - GRAND Elementary\116838-PLAN - GRAND Elementary.dwg

**SURVEY LEGEND**

⊕ AIR CONDITIONER	⊕ ELECTRIC MARKER	⊕ GAS MARKER	⊕ MISC. MARKER	⊕ SPRINKLER CONTROL VALVE	⊕ TREE	⊕ WATER MANHOLE
⊕ AREA SIGN OR CATCH BASIN	⊕ ELECTRIC UTILITY RISER	⊕ GREASE TRAP	⊕ PULLBOX	⊕ SANITARY SEWER LIFT STATION	⊕ TRAFFIC SIGNAL LIGHT	⊕ WATER SHUTOFF (SPRIG)
⊕ ALPHA BOX	⊕ FRENCH DRAIN	⊕ HC SIGN	⊕ POWER POLE WITH SERVICE	⊕ SEPTIC TANK	⊕ TV MANHOLE	⊕ WATER VALVE
⊕ AUTO SPRINKLER	⊕ FIRE HYDRANT	⊕ HC SIGN	⊕ QUARTER CORNER	⊕ STORM SEWER MANHOLE	⊕ TV PEDestal	⊕ WATER WELL
⊕ AIR VENT	⊕ FIRE VALVE	⊕ LIGHT POLE	⊕ QUARTER CORNER NORTH-SOUTH	⊕ TELEPHONE MANHOLE	⊕ YARD LIGHT	⊕ BM #1
⊕ PROF. MOK.	⊕ FLAG POLE	⊕ MAIL BOX	⊕ REFERENCE POINT	⊕ TELEPHONE PEDestal	⊕ YARD LIGHT	⊕ EL=XXXX'
⊕ CLEAN OUT	⊕ FIRE VALVE	⊕ MAIL BOX	⊕ SECTION CORNER	⊕ TELEPHONE PEDestal	⊕ YARD LIGHT	⊕ EL=XXXX'
⊕ DOWN SPOUT	⊕ GUY ANCHOR	⊕ MAIL BOX	⊕ SECTION CORNER	⊕ TELEPHONE PEDestal	⊕ YARD LIGHT	⊕ EL=XXXX'
⊕ ELECTRIC METER	⊕ GAS METER	⊕ MAIL BOX	⊕ SECTION CORNER	⊕ TELEPHONE PEDestal	⊕ YARD LIGHT	⊕ EL=XXXX'
⊕ ELECTRIC METER	⊕ GAS METER	⊕ MAIL BOX	⊕ SECTION CORNER	⊕ TELEPHONE PEDestal	⊕ YARD LIGHT	⊕ EL=XXXX'

— U/F — UNDERGROUND FIBER OPTIC	— U/G — UNDERGROUND GAS	— U/S — UNDERGROUND STORM SEWER	— U/W — UNDERGROUND WATER	— U/T — UNDERGROUND TELEVISION	— U/E — UNDERGROUND ELECTRIC	— U/C — UNDERGROUND CABLE
— T/B — TIE OF BANK	— T/P — TOP OF BANK	— C/W — CHANTRY FENCE	— S/F — STOCKADE FENCE	— O/E — OVERHEAD ELECTRIC	— O/T — OVERHEAD TELEVISION	— O/C — OVERHEAD CABLE

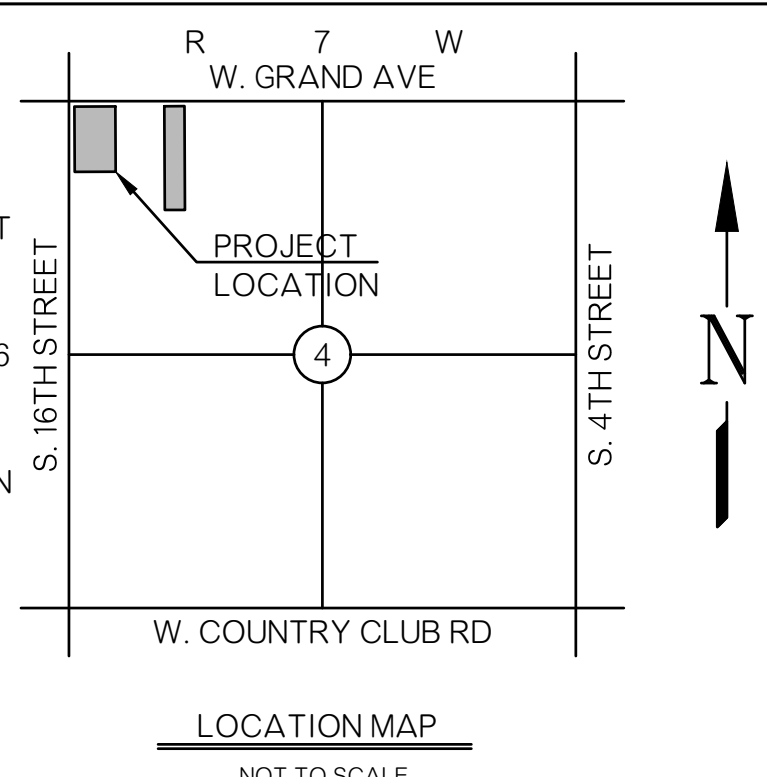
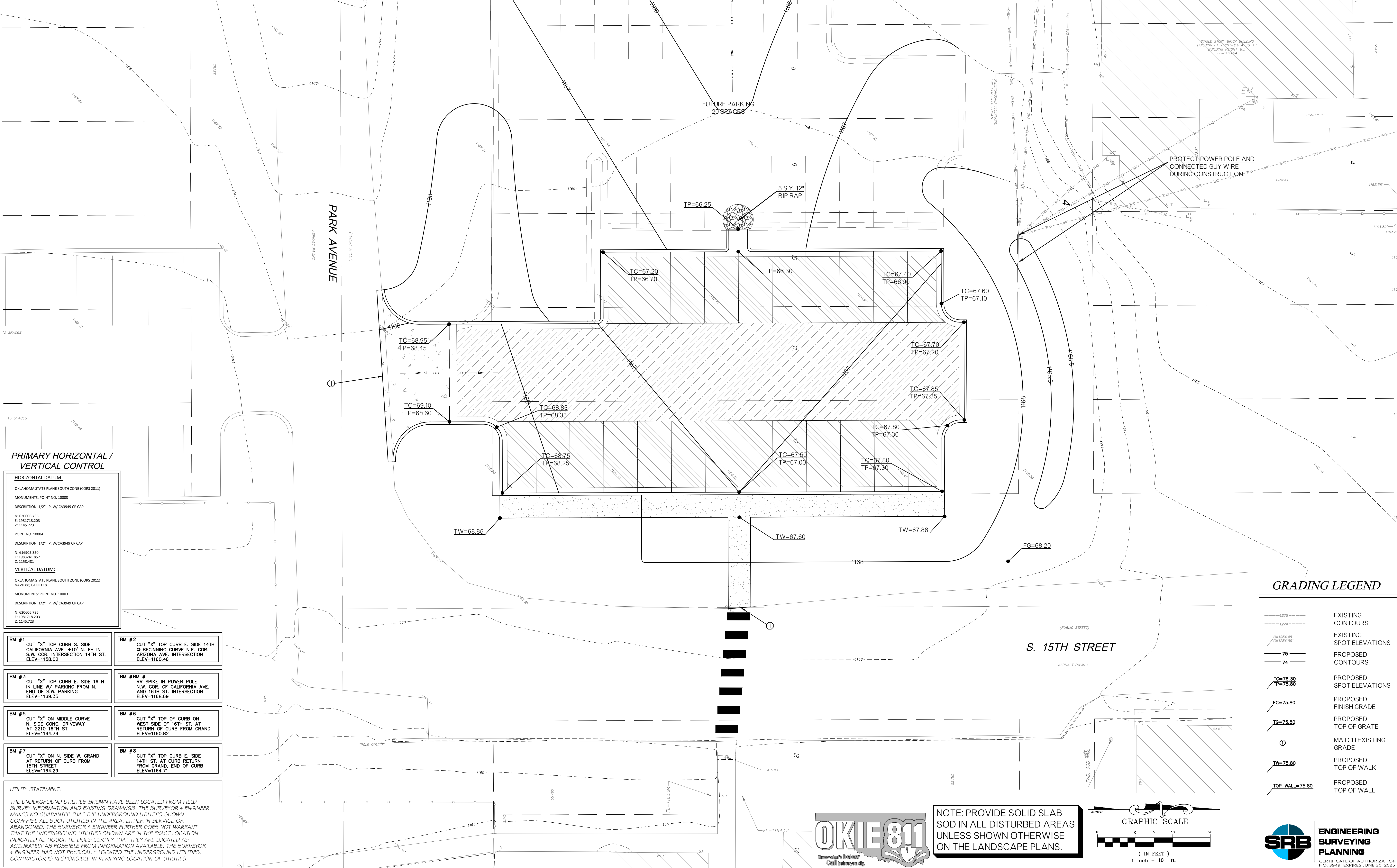

**LWPB**  
An LDG Company  
3817 NW EXPRESSWAY SUITE 500  
OKLAHOMA CITY, OK 73112  
(405) 722-7270



**CHICKASHA PUBLIC SCHOOLS  
GRAND AVENUE ELEMENTARY  
PARKING AND PAVING IMPROVEMENTS**  
1415 W. GRAND AVE., Chickasha, OK 73018

**PRIMARY HORIZONTAL / VERTICAL CONTROL**

**HORIZONTAL DATUM:**  
OKLAHOMA STATE PLANE SOUTH ZONE (CDRS 2011)  
MONUMENTS: POINT NO. 10003  
DESCRIPTION: 1/2" I.P. W/ CA3949 CP CAP  
N: 620606.736  
E: 1981718.203  
Z: 1145.723  
POINT NO. 10004  
DESCRIPTION: 1/2" I.P. W/ CA3949 CP CAP  
N: 616905.300  
E: 198341.857  
Z: 1138.481

**VERTICAL DATUM:**  
OKLAHOMA STATE PLANE SOUTH ZONE (CDRS 2011)  
NAVD 88: GEOID 88  
MONUMENTS: POINT NO. 10003  
DESCRIPTION: 1/2" I.P. W/ CA3949 CP CAP  
N: 620606.736  
E: 1981718.203  
Z: 1145.723

<b>BM #1</b> CUT "X" TOP CURB S. SIDE CALIFORNIA AVE. ±10' N. FH IN S.W. COR. INTERSECTION 14TH ST. ELEV=1158.02	<b>BM #2</b> CUT "X" TOP CURB E. SIDE 14TH ST. BEGINNING CURVE N.E. COR. ARIZONA AVE. INTERSECTION ELEV=1160.46
<b>BM #3</b> CUT "X" TOP CURB E. SIDE 16TH ST. IN LINE W/ PARKING FROM N. END OF S.W. PARKING ELEV=1169.35	<b>BM #4</b> RR SPIKE IN POWER POLE N.W. COR. OF CALIFORNIA AVE. AND 16TH ST. INTERSECTION ELEV=1169.69
<b>BM #5</b> CUT "X" ON MIDDLE CURVE N. SIDE CONC. DRIVEWAY AT 2210 16TH ST. ELEV=1164.79	<b>BM #6</b> CUT "X" TOP OF CURB ON WEST SIDE OF 16TH ST. AT RETURN OF CURB FROM GRAND ELEV=1160.82
<b>BM #7</b> CUT "X" ON N. SIDE W. GRAND AT RETURN OF CURB FROM 15TH STREET ELEV=1164.29	<b>BM #8</b> CUT "X" TOP CURB E. SIDE 14TH ST. AT CURB RETURN FROM GRAND. END OF CURB ELEV=1164.71

**UTILITY STATEMENT:**  
THE UNDERGROUND UTILITIES SHOWN HAVE BEEN LOCATED FROM FIELD SURVEY INFORMATION AND EXISTING DRAWINGS. THE SURVEYOR & ENGINEER MAKES NO GUARANTEE THAT THE UNDERGROUND UTILITIES SHOWN COMPRISE ALL SUCH UTILITIES IN THE AREA, EITHER IN SERVICE OR ABANDONED. THE SURVEYOR & ENGINEER FURTHER DOES NOT WARRANT THAT THE UNDERGROUND UTILITIES SHOWN ARE IN THE EXACT LOCATION INDICATED ALTHOUGH HE DOES CERTIFY THAT THEY ARE LOCATED AS ACCURATELY AS POSSIBLE FROM INFORMATION AVAILABLE. THE SURVEYOR & ENGINEER HAS NOT PHYSICALLY LOCATED THE UNDERGROUND UTILITIES. CONTRACTOR IS RESPONSIBLE IN VERIFYING LOCATION OF UTILITIES.

**GRADING LEGEND**

---	EXISTING CONTOURS
---	EXISTING SPOT ELEVATIONS
---	PROPOSED CONTOURS
---	PROPOSED SPOT ELEVATIONS
---	PROPOSED FINISH GRADE
---	PROPOSED TOP OF GRATE
---	MATCH EXISTING GRADE
---	PROPOSED TOP OF WALK
---	PROPOSED TOP OF WALL

JOB NO:	116838 TASK 1
DATE:	02/13/2014
REVISIONS:	

DRAWING TITLE  
GRADING PLAN - WEST PARKING

**C4.0**

LOCAL FILE: BIM\_380/Kingfisher 2022 Gilmore and Football Concession Renovations/2022 Gilmore Elementary.rvt  
CENTRAL FILE: 2/19/2023 2:53:52 PM  
LWPB JOB: 22-1511-E906  
TEMPLATE: LWPB 2019.0002  
Z:\116838\Private Site Development\Task 1 - Grand Elementary\116838-PLAN - GRAND.san.marzano.2.13.24.04.1.rvt



NOTE: PROVIDE SOLID SLAB SOD IN ALL DISTURBED AREAS UNLESS SHOWN OTHERWISE ON THE LANDSCAPE PLANS.

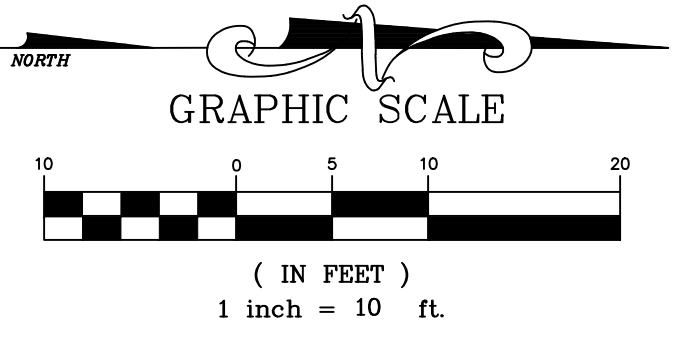





An LDG Company

3817 NW EXPRESSWAY  
SUITE 840  
OKLAHOMA CITY, OK 73112  
(405) 722-7270



CHICKASHA PUBLIC SCHOOLS  
GRAND AVENUE ELEMENTARY  
PARKING AND PAVING IMPROVEMENTS  
1415 W. GRAND AVE, Chickasha, OK 73018

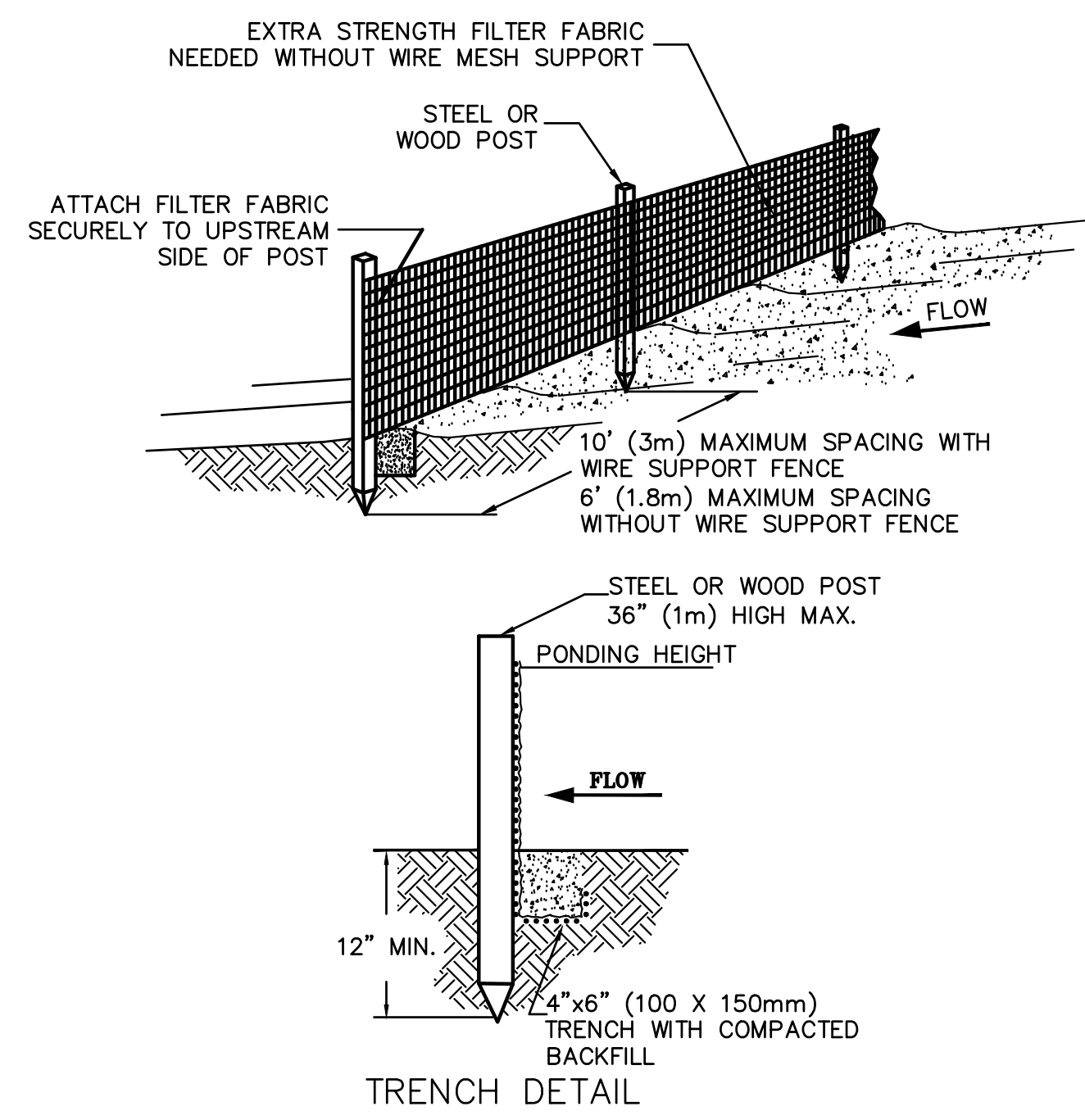

- NOTES:
1. SILT FENCE SHALL BE PLACED ON SLOPE CONTOURS TO MAXIMIZE PONDING EFFICIENCY.
2. INSPECT AND REPAIR FENCE AFTER EACH STORM EVENT AND REMOVE SEDIMENT WHEN NECESSARY. 9" (225mm) MAXIMUM RECOMMENDED STORAGE HEIGHT.
3. REMOVED SEDIMENT SHALL BE DEPOSITED TO AN AREA THAT WILL NOT CONTRIBUTE SEDIMENT OFF-SITE AND CAN BE PERMANENTLY STABILIZED.

SILT FENCE DETAIL
NO SCALE

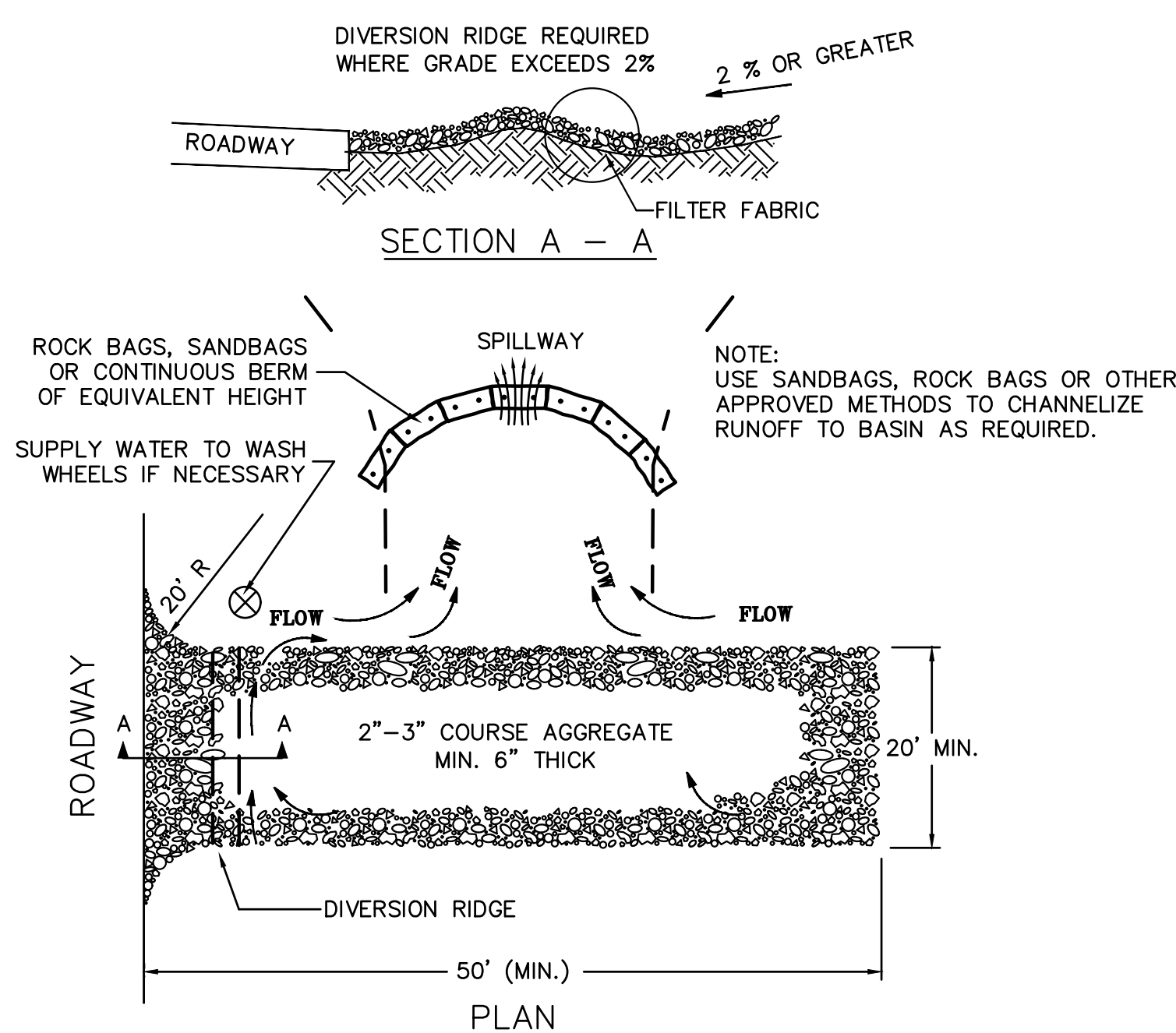

- NOTES:
1. THE ENTRANCE SHALL BE MAINTAINED IN A CONDITION THAT WILL PREVENT TRACKING OR FLOWING OF SEDIMENT ONTO PUBLIC RIGHT-OF-WAYS. THIS MAY REQUIRE TOP DRESSING, REPAIR AND/OR CLEANOUT OF ANY MEASURES USED TO TRAP SEDIMENT.
2. WHEN NECESSARY, WHEELS SHALL BE CLEANED PRIOR TO ENTRANCE ONTO PUBLIC RIGHT-OF-WAY.
3. WHEN WASHING IS REQUIRED, IT SHALL BE DONE ON AN AREA STABILIZED WITH CRUSHED STONE THAT DRAINS INTO AN APPROVED SEDIMENT TRAP OR SEDIMENT BASIN.

TEMPORARY CONSTRUCTION ENTRANCE
NO SCALE

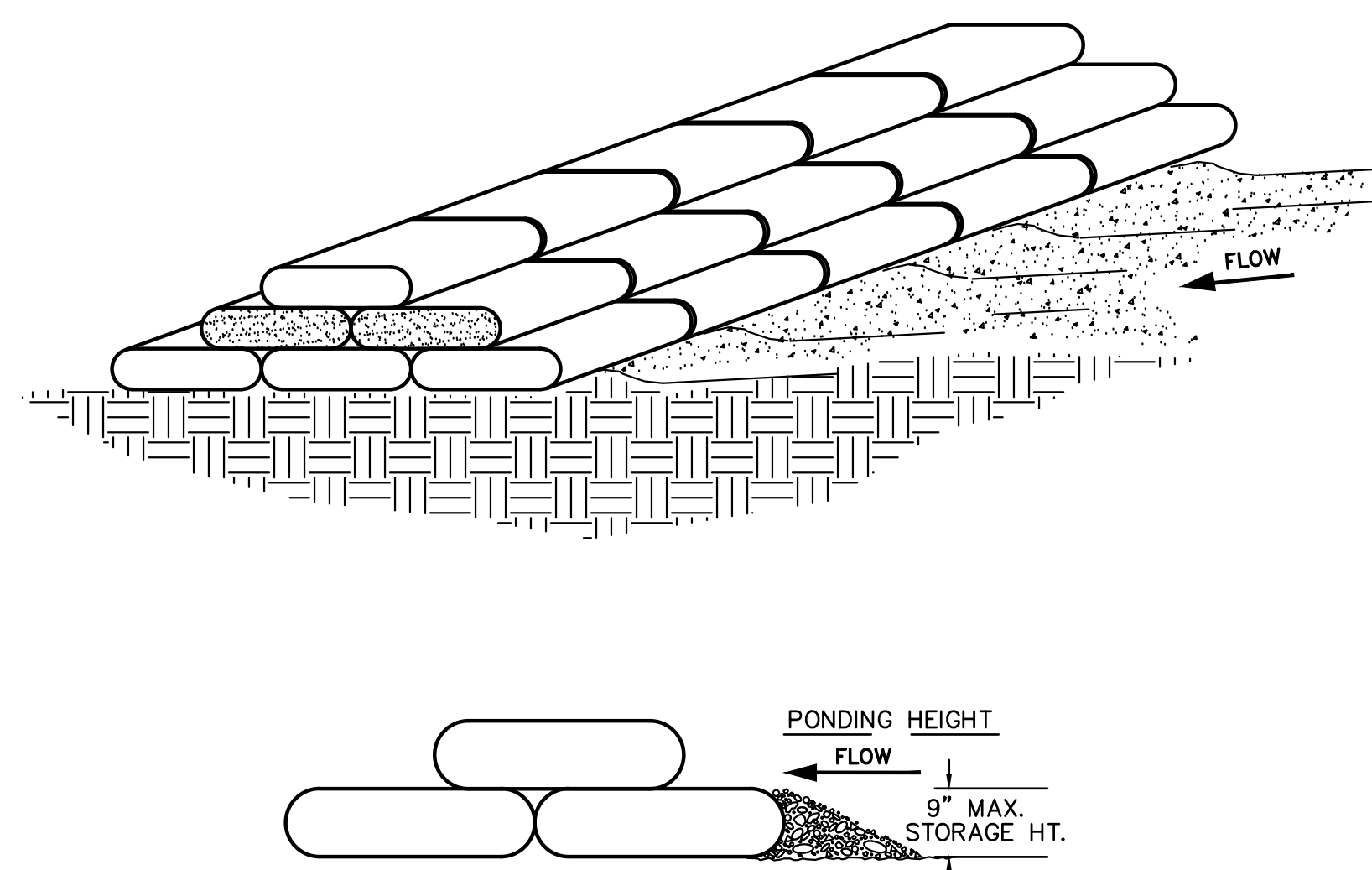

- NOTES:
1. A 'REASONABLE' DESIGN SIZE PARTICLE MUST BE SELECTED.
2. SIZE DISTRIBUTION FOR UPSTREAM SOIL PARTICLES MUST BE EVALUATED.
3. INFLOW AND OUTFLOW FROM THE SYSTEM FOR A SPECIFIC FREQUENCY STORM MUST BE KNOWN.
4. POND VOLUME IS DIRECTLY PROPORTIONAL TO THE DISCHARGE RATE OF THE SYSTEM.
5. POND VOLUME IS INVERSELY SUFFICIENT FLOW TO ALLOW FOR DEPOSITION OF DESIGN PARTICLES.
6. A SYSTEM MUST PROVIDE SUFFICIENT FLOW TO ALLOW FOR DEPOSITION OF DESIGN PARTICLES.
7. THE PONDING HEIGHT MUST BE WELL BELOW THE GROUND ELEVATION DOWN SLOPE TO PREVENT RUNOFF FROM BYPASSING THE INLET. A TEMPORARY DIKE MAY BE NECESSARY ON THE DOWN SLOPE SIDE OF THE STRUCTURE.
8. ROCK BAG SILT BARRIER SHALL BE PLACED ON SLOPE CONTOURS TO MAXIMIZE POUNDING EFFICIENCY.
9. PLACE ROCK BAG SUCH THAT NO GAPS ARE EVIDENT.
10. INSPECT AND REPAIR FENCE AFTER EACH STORM EVENT AND REMOVE SEDIMENT WHEN NECESSARY. 9" MAXIMUM RECOMMENDED STORAGE HEIGHT.
11. REMOVED SEDIMENT SHALL BE DEPOSITED TO AN AREA THAT WILL NOT CONTRIBUTE TO SEDIMENT OFF-SITE AND CAN BE PERMANENTLY STABILIZED.

ROCK BAG DETAIL
NO SCALE

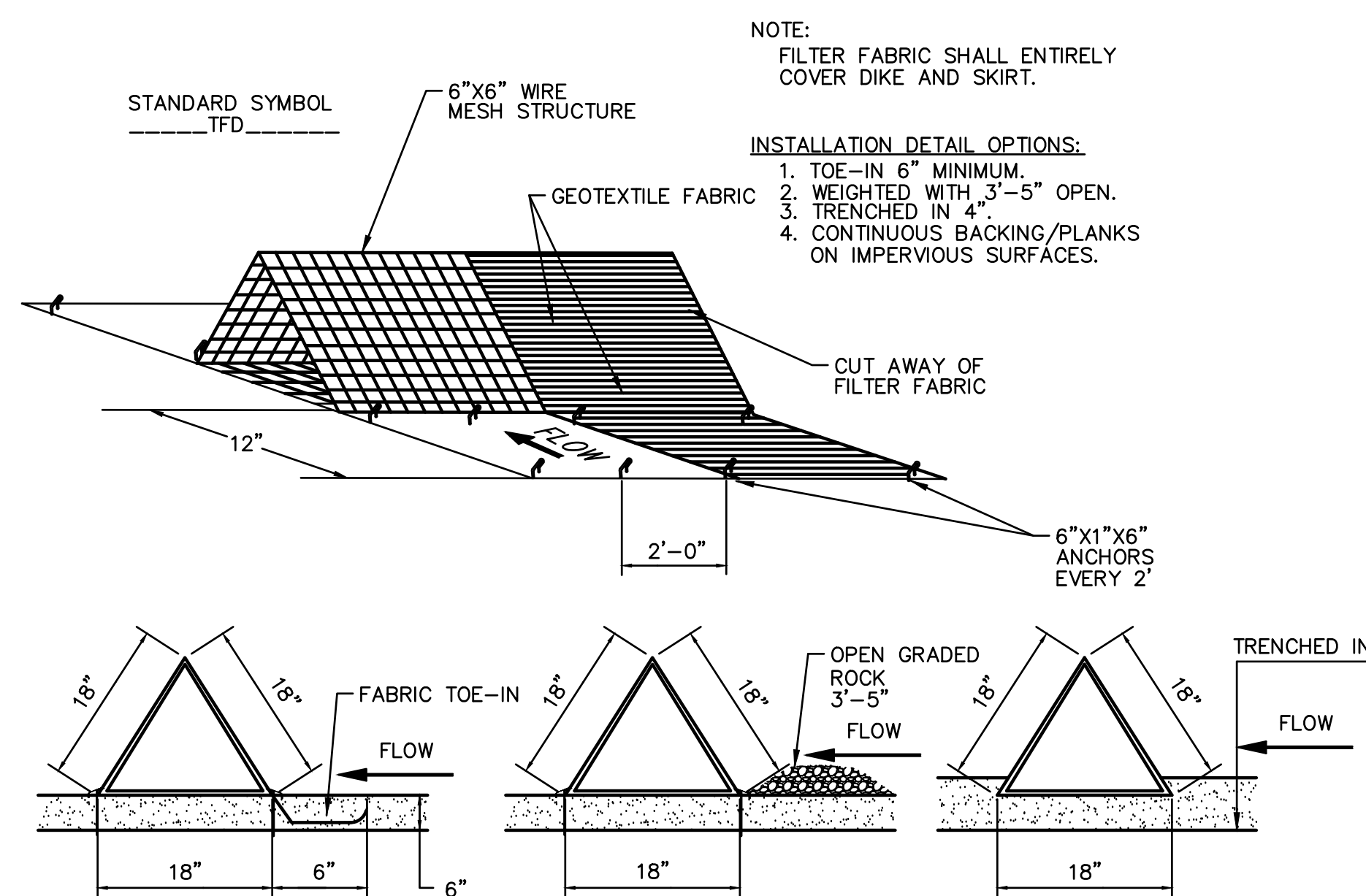

- GENERAL NOTES:
1. DIKES SHALL BE PLACED IN A ROW WITH ENDS TIGHTLY ABUTTING THE ADJACENT DIKE.
2. THE FABRIC COVER AND SKIRT SHALL BE A CONTINUOUS WRAPPING OF GEOTEXTILE. THE SKIRT SHALL BE A CONTINUOUS EXTENSION OF THE FABRIC ON THE UPSTREAM FACE.
3. THE SKIRT SHALL BE WEIGHTED WITH A CONTINUOUS LAYER OF 3'-5" OPEN GRADED ROCK OR TOED-IN 150 mm (6") WITH MECHANICALLY COMPACTED MATERIAL. OTHERWISE, THE ENTIRE STRUCTURE SHALL BE TRENCHED IN 4".
4. DIKES AND SKIRT SHALL BE SECURELY ANCHORED IN PLACE USING 6" WIRE STAPLES ON 2'-0" CENTERS ON BOTH EDGES AND SKIRT, OR STAKE USING 3/8" DIAMETER RE-BAR WITH TEE ENDS.
5. FILTER MATERIAL SHALL BE LAPPED OVER ENDS 6" TO COVER DIKE TO DIKE JOINTS. JOINTS SHALL BE FASTENED WITH GALVANIZED SHOAT RINGS.
6. THE DIKE STRUCTURE SHALL BE MW 6 GA. 6"x6" WIRE MESH, 18" ON A SIDE.
7. INSPECTION SHALL BE MADE WEEKLY OR AFTER EACH RAINFALL EVENT AND REPAIR OR REPLACEMENT SHALL BE MADE PROMPTLY AS NEEDED BY THE CONTRACTOR.
8. ACCUMULATED SILT SHALL BE REMOVED WHEN IT REACHES A DEPTH OF 6" AND DISPOSED OF IN A MANNER WHICH SHALL NOT CAUSE ADDITIONAL SILTATION.
9. AFTER THE DEVELOPMENT SITE IS COMPLETELY STABILIZED, THE DIKES AND ANY REMAINING SILT SHALL BE REMOVED. SILT SHALL BE DISPOSED OF AS INDICATED IN GENERAL NOTE 8 ABOVE.

TRIANGULAR SILT DIKE
NO SCALE



CERTIFICATE OF AUTHORIZATION  
NO. 5949 EXPIRES JUNE 30, 2025

DRAWING TITLE  
EROSION CONTROL  
DETAILS

C5.2

JOB NO: 116838 TASK 1  
DATE: 02/13/2014

REVISIONS

LOCAL FILE: B:\116838\Kingsfisher 2022 Gilmore and Football Concession Renovations\2022 Gilmore Elementary.rvt  
CENTRAL FILE: 2/9/2023 2:53:52 PM  
LWPB JOB: 22-1511-E008  
DRAWN BY: LWPB 2019.0002  
Z:\116838\Private\_Site\_Development\Task 1 - Grand Elementary\116838-PLAN - GRAND.ssm.maazano 2.13.24, 04:11pm